

FRS1

ROYAL NAVY SEA HARRIER FRS1

The Sea Harrier is a naval vertical/short takeoff and landing (V/STOL) jet fighter, reconnaissance and attack aircraft. The first version entered service with the Royal Navy's Fleet Air Arm in April 1980 as the Sea Harrier FRS.1, and was informally known as the Shar.

During the 1982 Falklands/Malvinas conflict, the HMS Invincible and HMS Hermes were dispatched to the South Atlantic along with all available surface combatants and support vessels. The FRS.1 provided air defense support to the fleet and to the troops ashore and did a credible job against the Argentine Air Force and Naval air forces operating from their home bases on the mainland. With the help of the last-minute upgrade to employ the all-aspect AIM-9L Sidewinder, the Harrier FRS.1 was able to achieve 21 kills without any air-to-air losses.

CAUTION

- *Read carefully and fully understand the instructions before commencing assembly.
- *Keep out of reach of children. Children must not be allowed to put any parts in their mouths, or pull plastic bag over their heads.
- *When using adhesives and paints, please make sure not to use them in closed room or near the fire.
- *When assembling this kit, tools including knives are used. Extra care should be taken to avoid injury.

WARNING: CONTAIN SMALL PARTS NOT FOR CHILDREN UNDER 14 YEARS OF AGE.



TOOLS RECOMMENDED

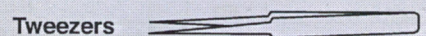
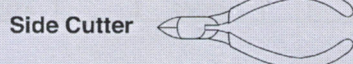

1/48 SCALE AIRCRAFT SERIES NO: K48035

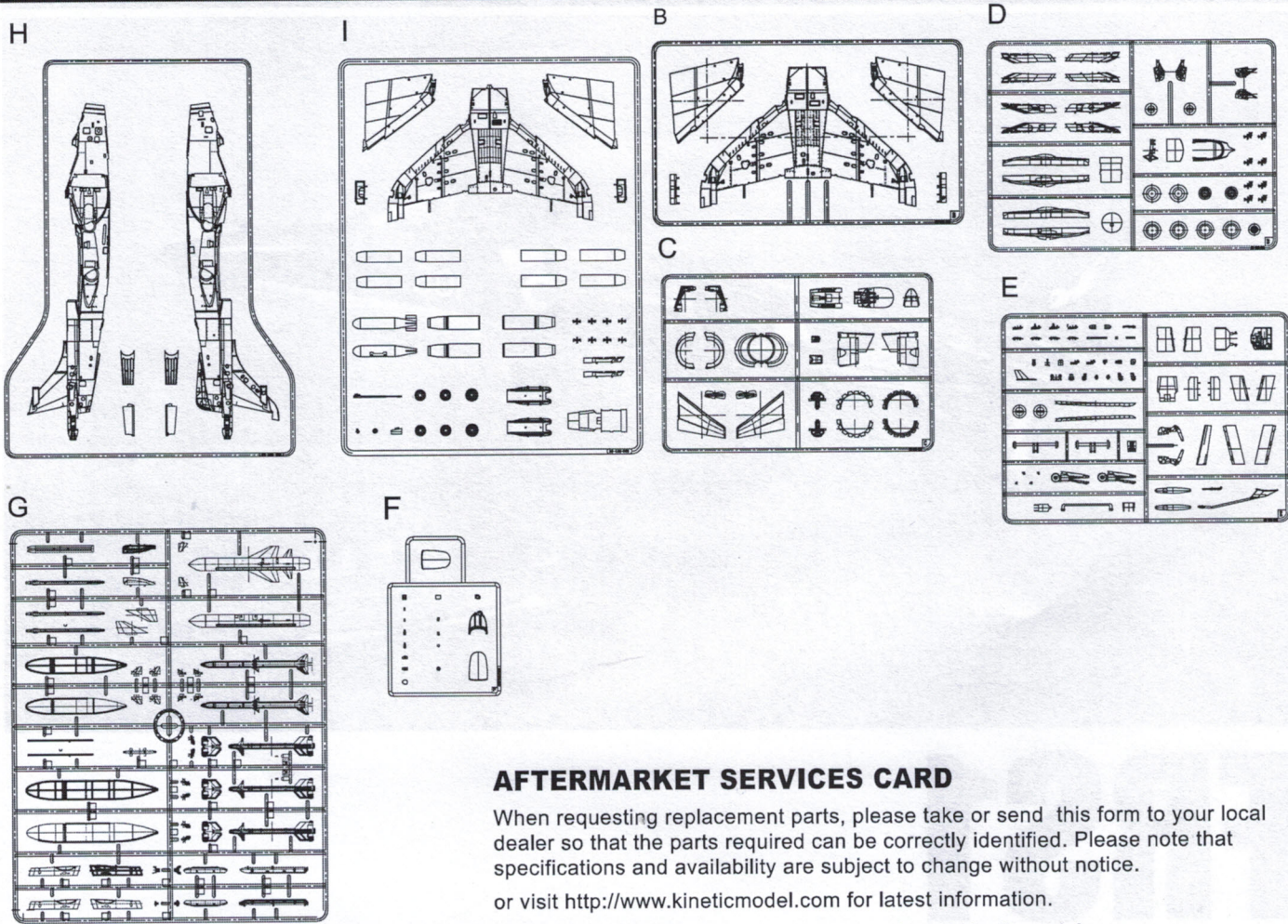

AFTERMARKET SERVICES CARD

When requesting replacement parts, please take or send this form to your local dealer so that the parts required can be correctly identified. Please note that specifications and availability are subject to change without notice.

or visit <http://www.kineticmodel.com> for latest information.

For more information, please contact services@kineticmodel.com

PARTS CODE	ITEM	K48035
00-156-002	B	1/48 HARRIER FA2 WINGS
00-156-003	C	1/48 HARRIER INTAKE
00-156-004	D	1/48 HARRIER PARTS
00-156-005	E	1/48 HARRIER LANDING GEAR
00-156-006	F	1/48 HARRIER CLEAR PARTS
00-156-007	G	1/48 HARRIER MISSILE SPRUE/TANK
00-156-008	H	1/48 HARRIER FRS1 FUESLAGE
00-156-009	I	1/48 HARRIER WINGS PARTS
01-156-48035	DECAL	1/48 HARRIER
106-156-48041	PE	1/48 HARRIER PE

PAINT INDEX

COLOR	BSC	HUMBROL ENAMEL/ACRYLIC	GSI CREOS MR. COLOR	ITALERI ARCYLIC PAINT	TAMIYA ENAMEL/ACRYLIC	AMMO MIG	VALLEJO MODEL COLOF MODEL AIR
FLAT BLACK		33	33	4768AP	XF-18	46	950 57
FLAT WHITE		130	1	4796AP	X-2	47	951 1
CLEAR RED		1321	47	-	-	93	934 -
CLEAR GREEN		1325	138	-	-	92	- -
US Ghost Grey		127	308	4762AP	-	203	- -
Gun Metal		53	78	4681AP	-	45	- -
KHAKI GREY		26	80	-	-	56	880 -
STEEL GREY		87	-	-	-	212	- -
BS 381C Extra Dark Sea Grey	640	134	333	4681AP	AS4	-	866 18
BS 381C Medium Sea Grey	637	145	335	4313AP	XF-83	-	870 -
BS 381C - Dark Sea Grey	638	79	331	4312AP	XF-77	205	868 48
BS 381C - Light Grey	631	-	-	4765AP	AS18	207	- 128

33 denotes Humbrol Paints

1

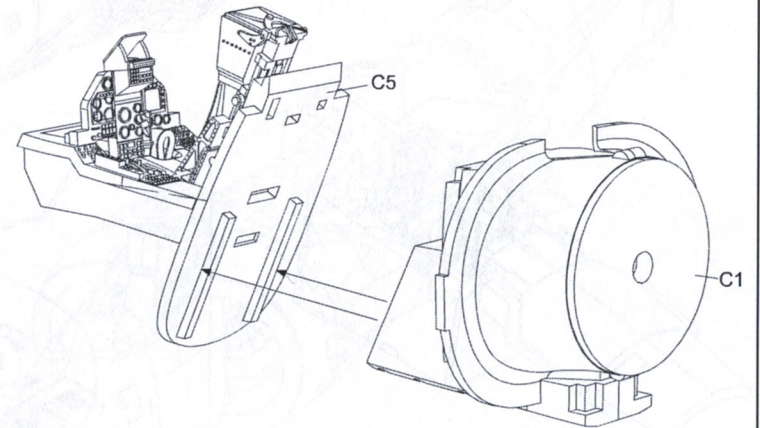
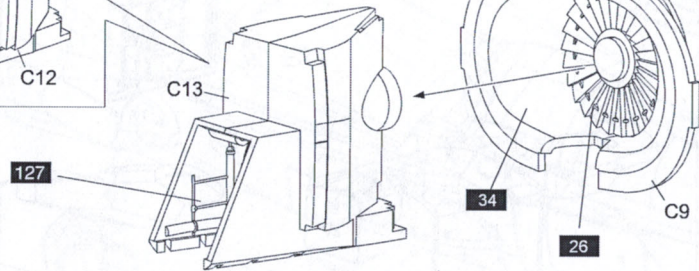
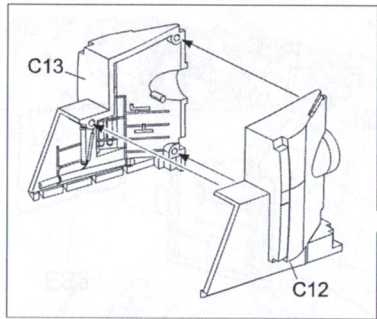
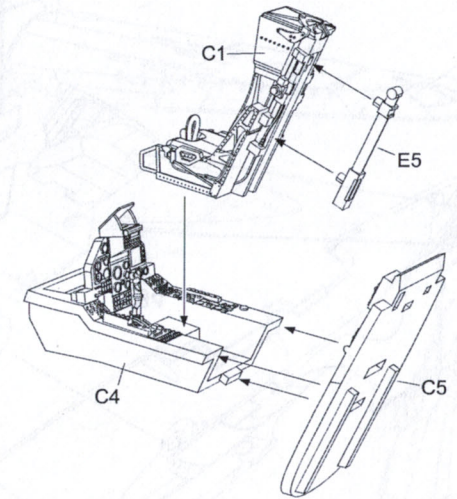
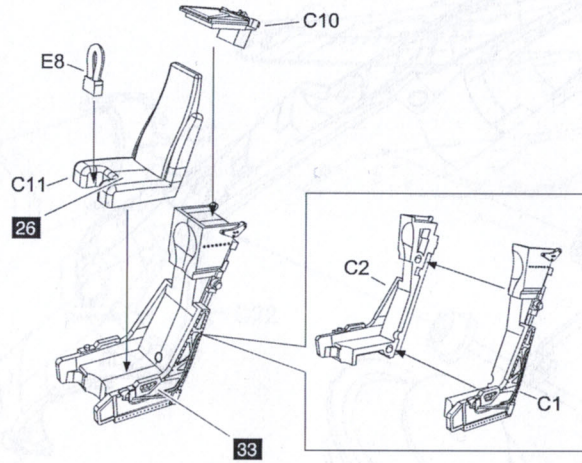
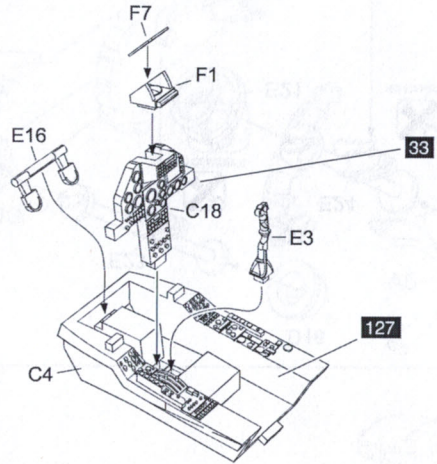

2



Optional
Air Brake Closed

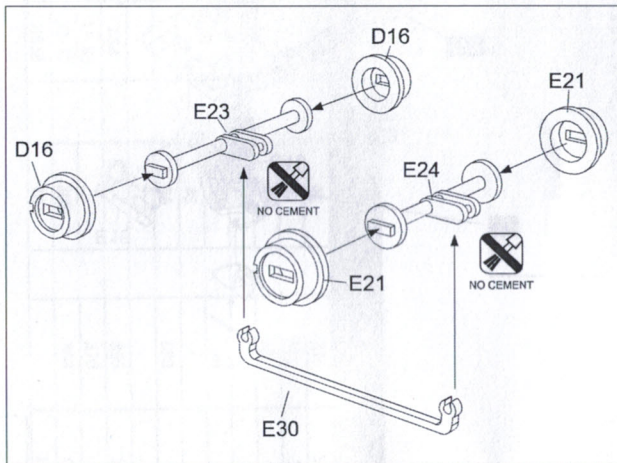
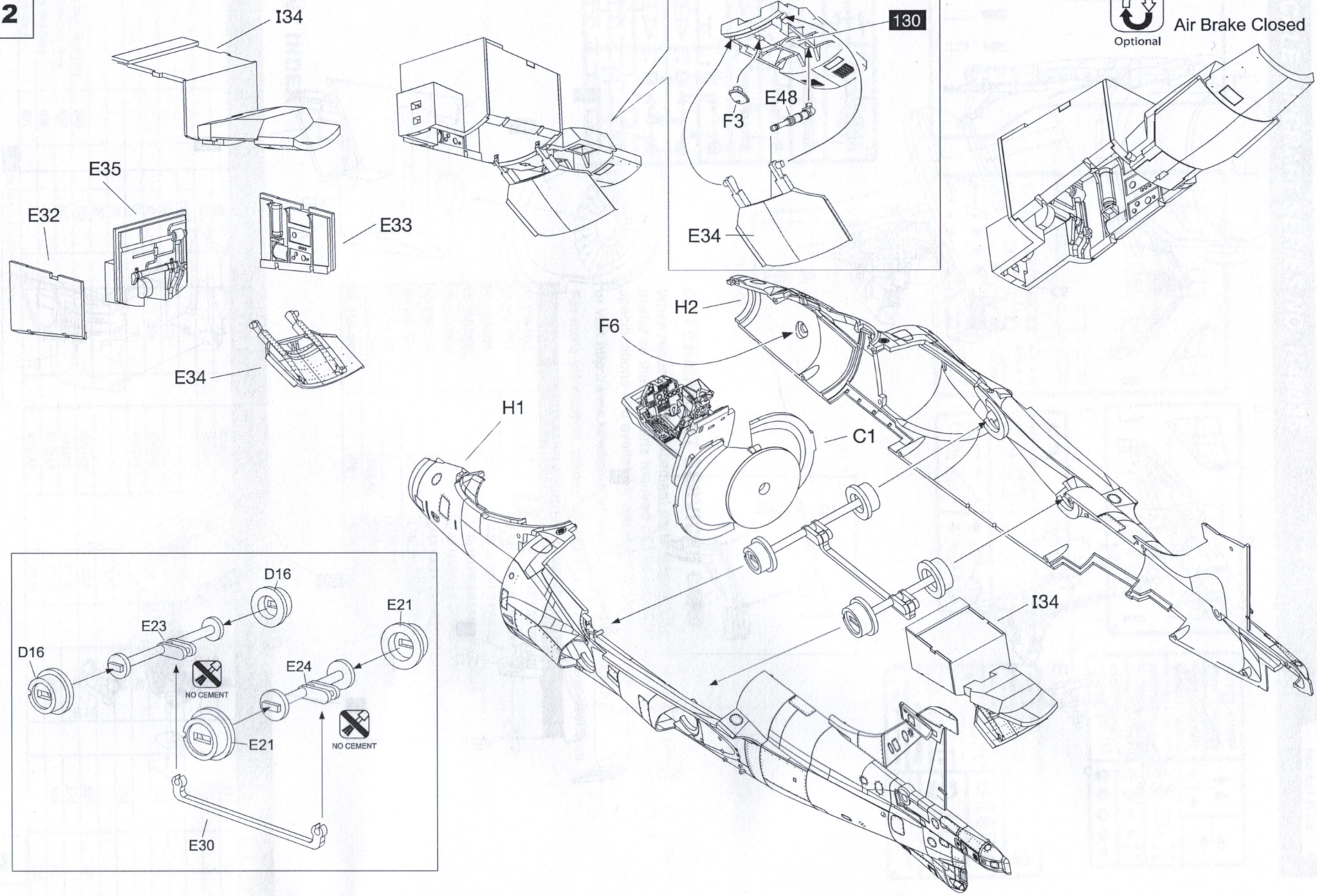

P4

3

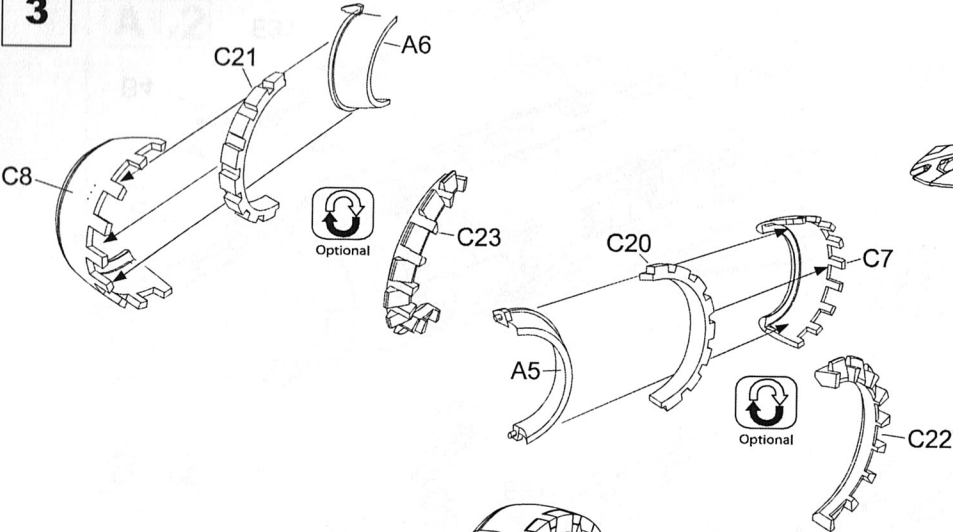

4

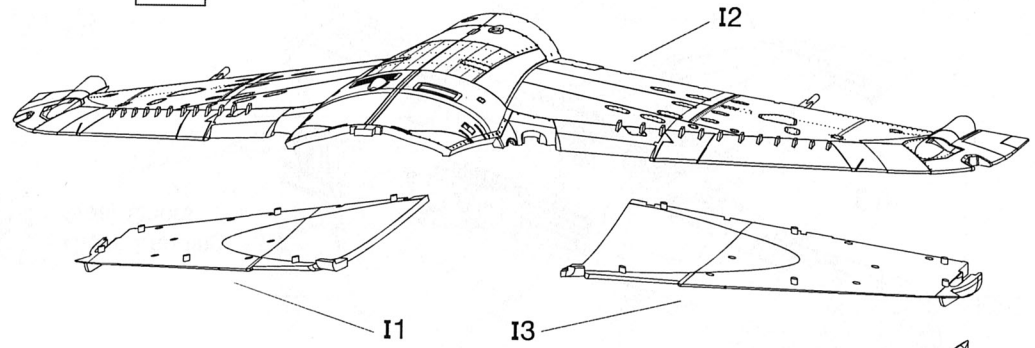

PS

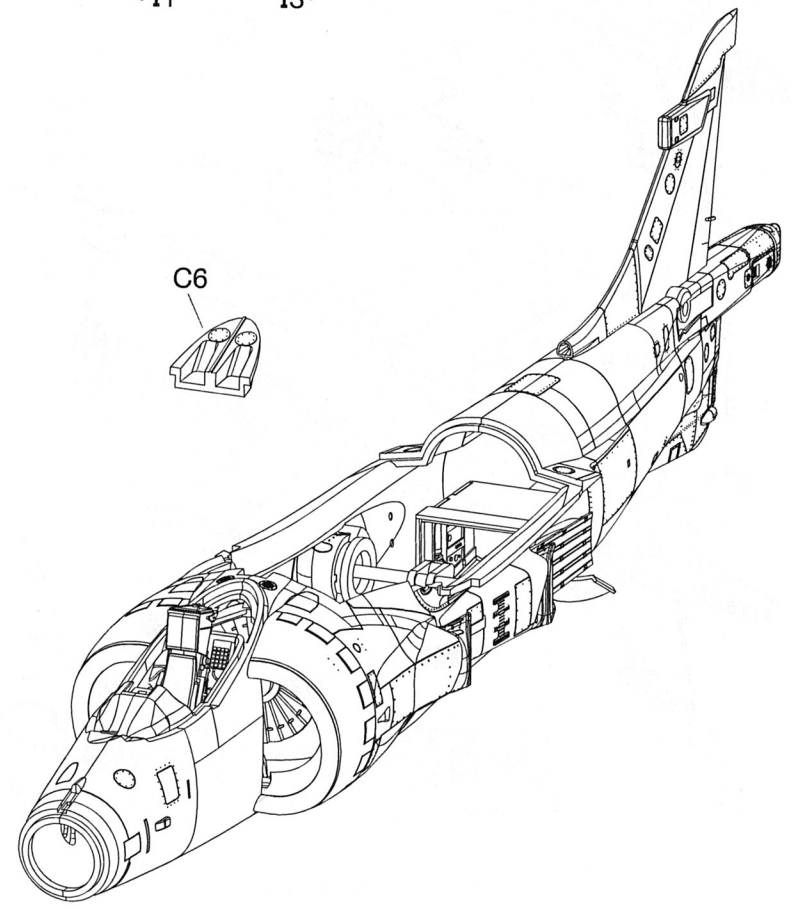
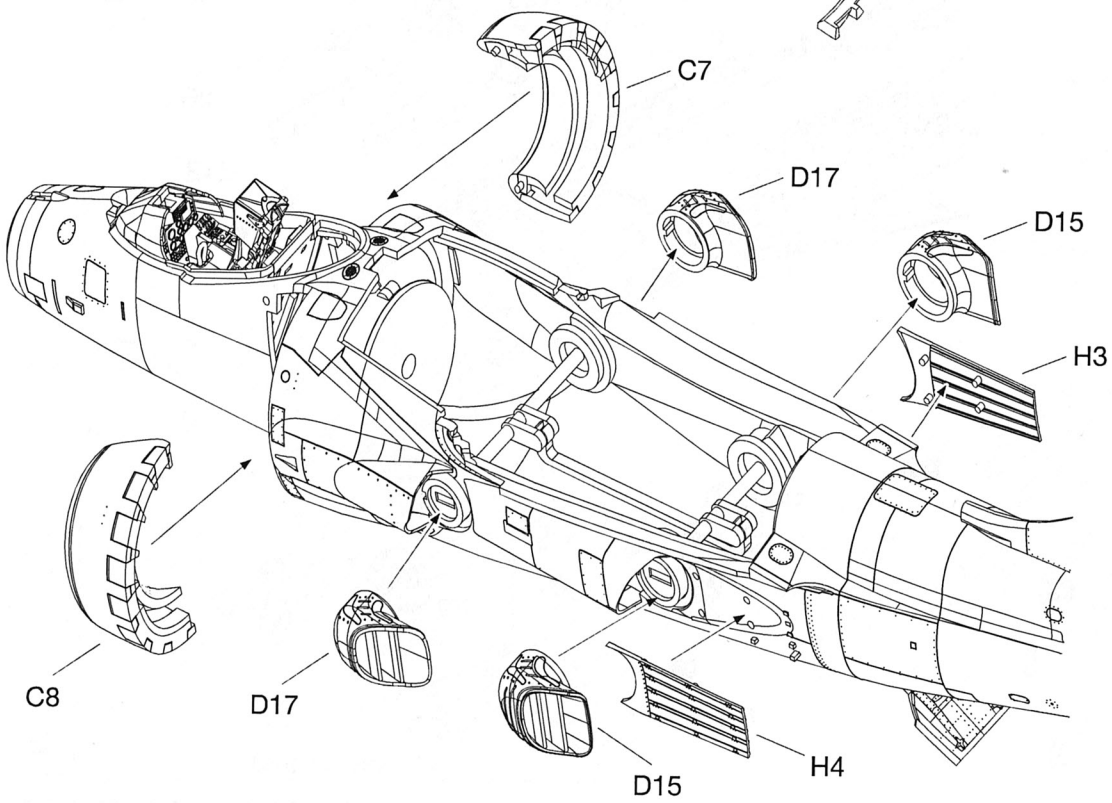

5

Front Wheel

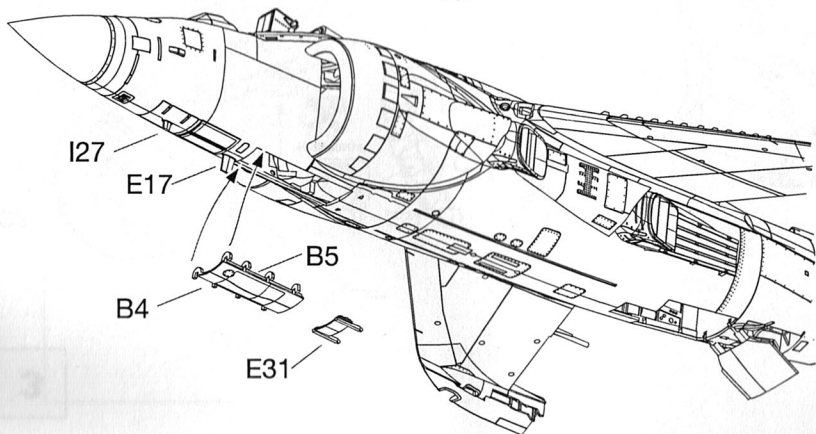
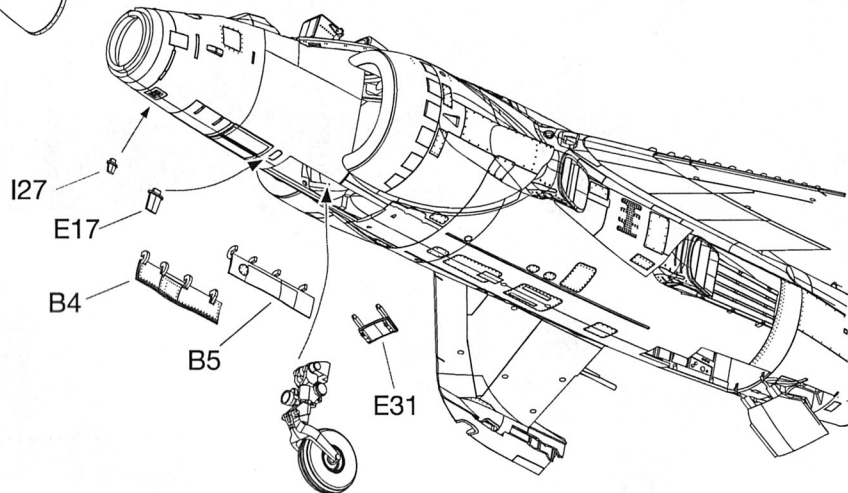
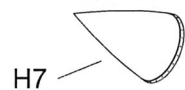
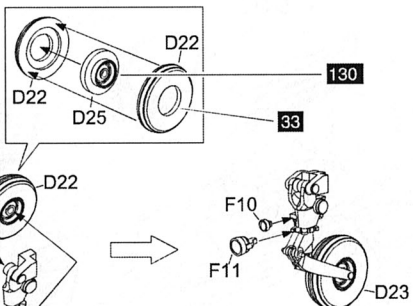

6

Rear Wheel

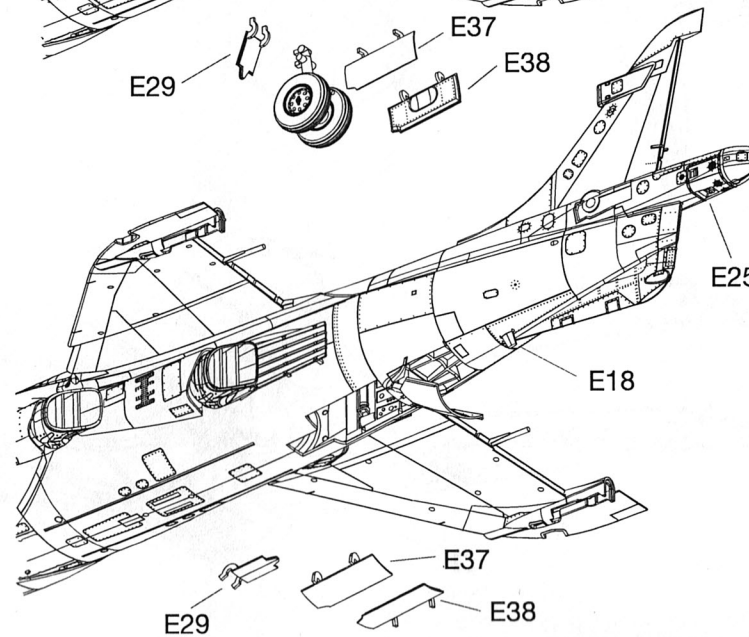
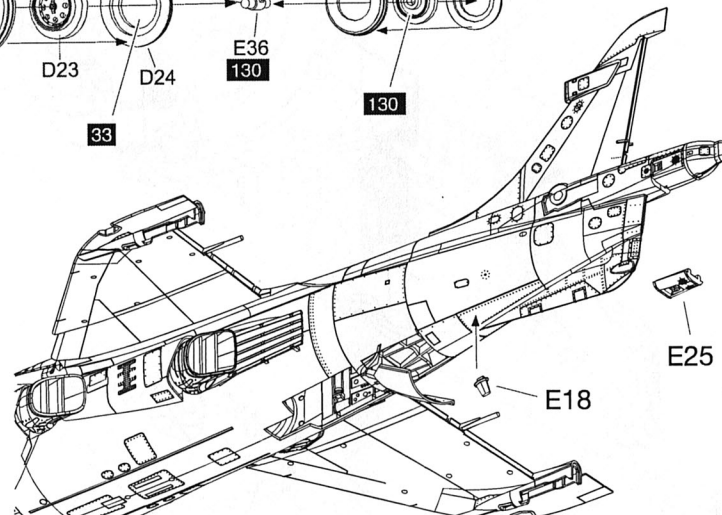
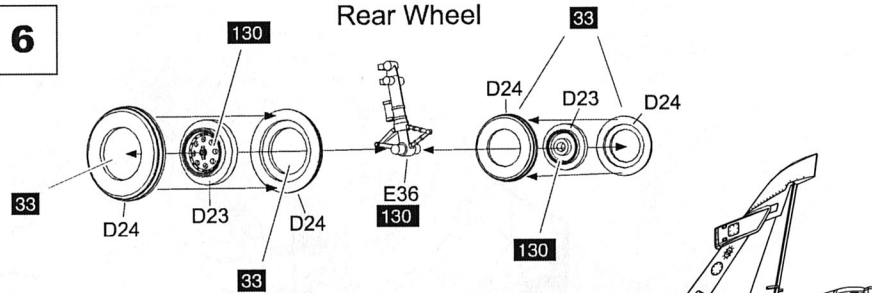

Close Landing Gear Doors

7

A x2

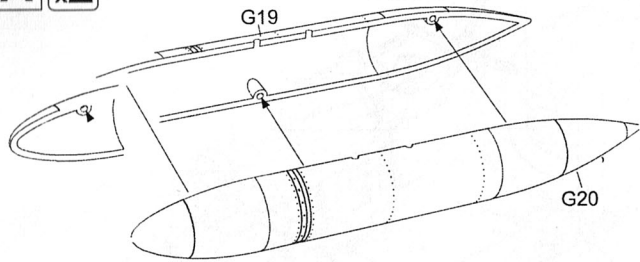

B x2

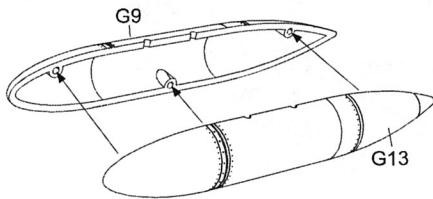

C x2

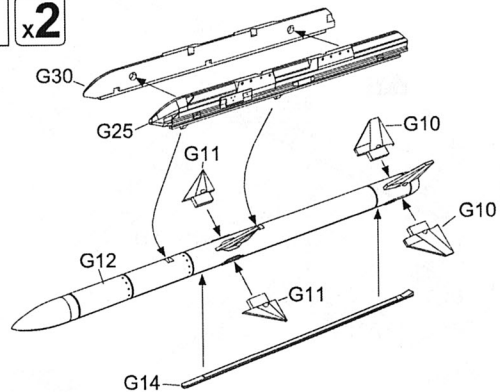

D x2

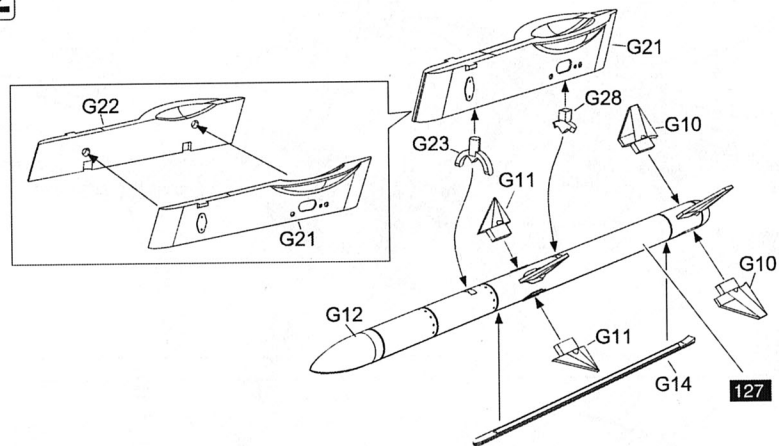

E x2

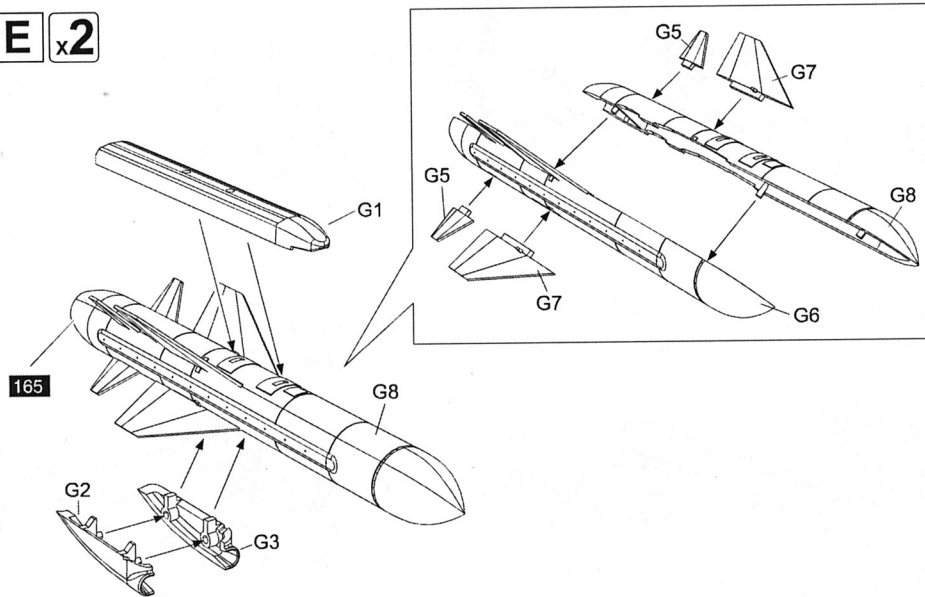

8

F x4

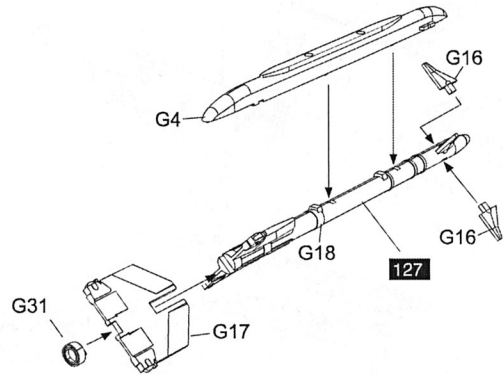

G x2

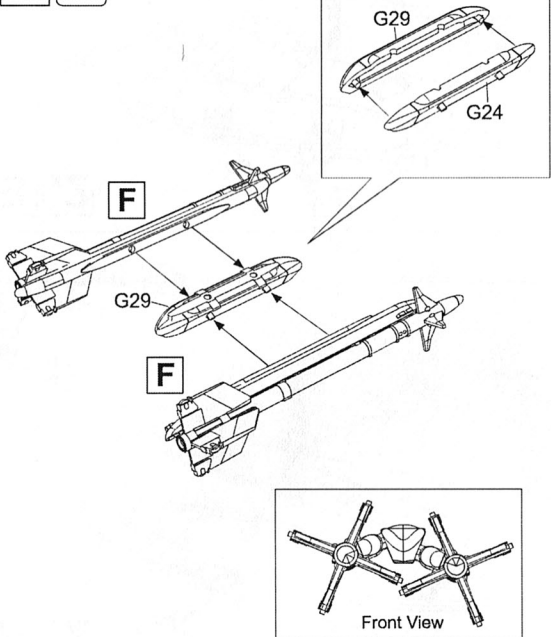

H

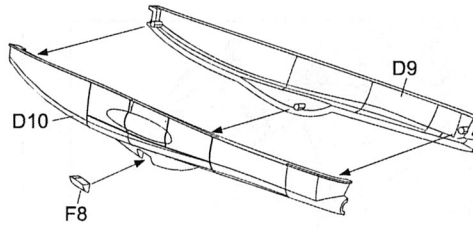

I

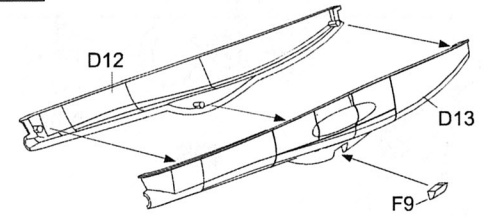

J x2

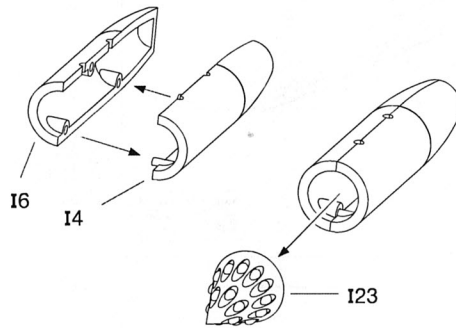

x2

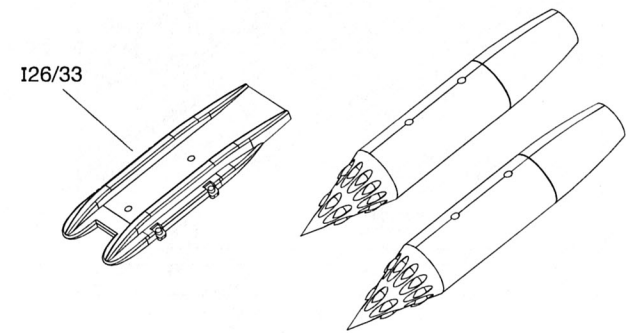

K

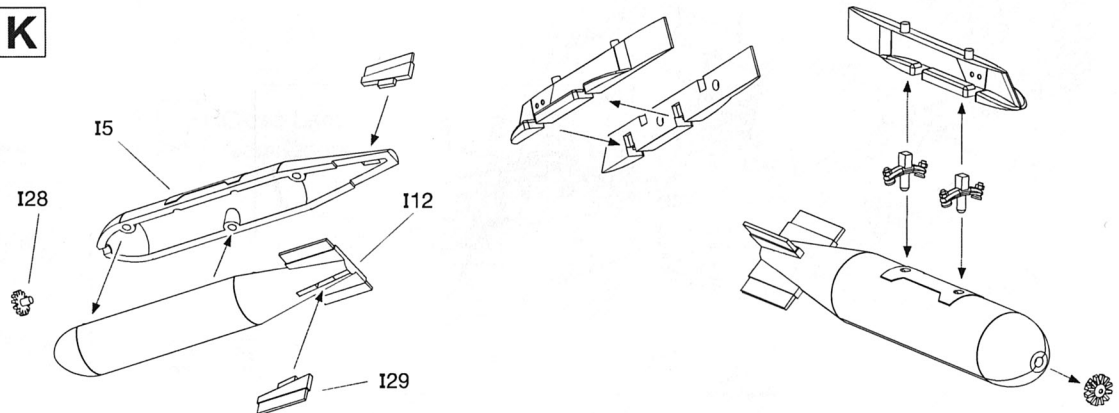

9

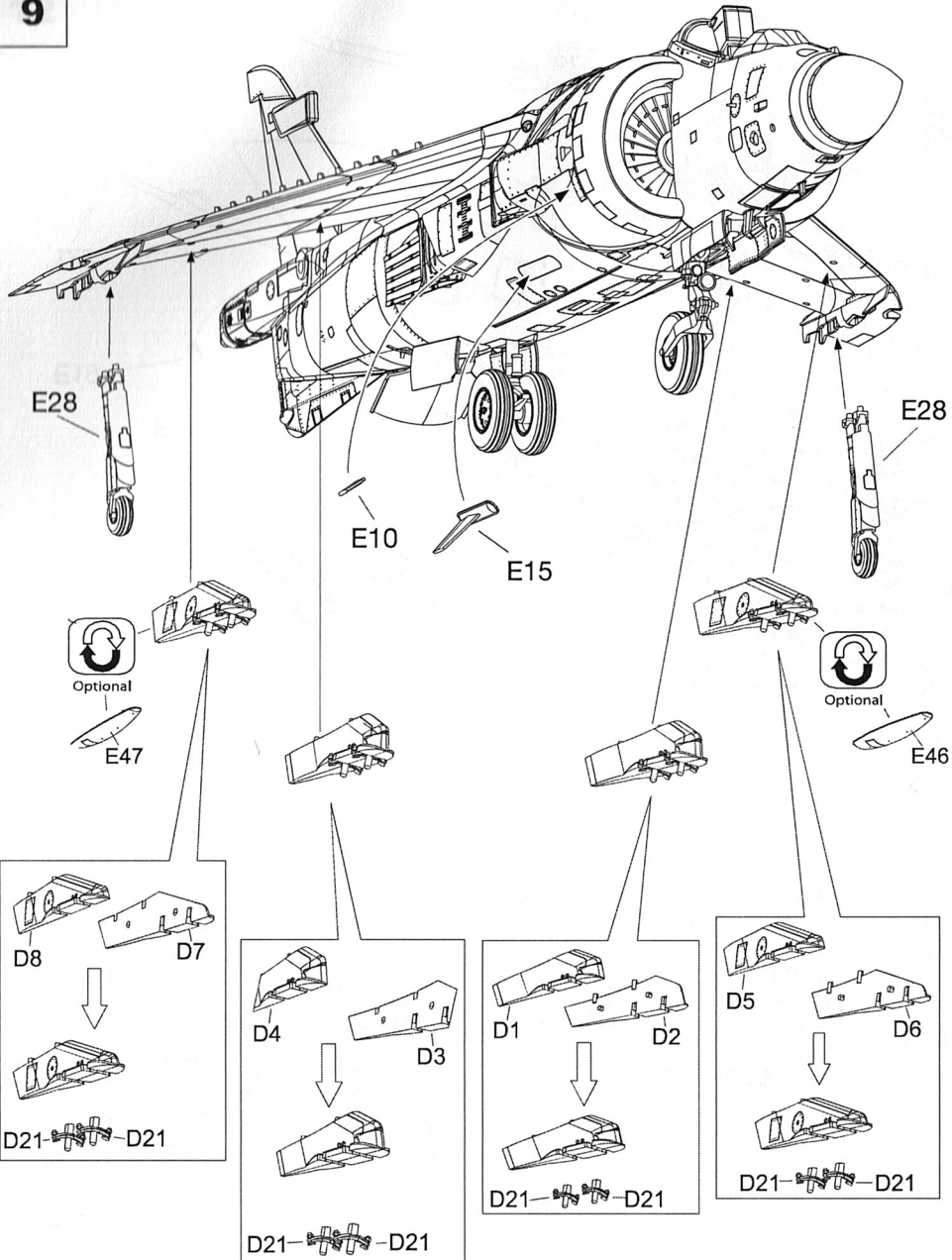

10

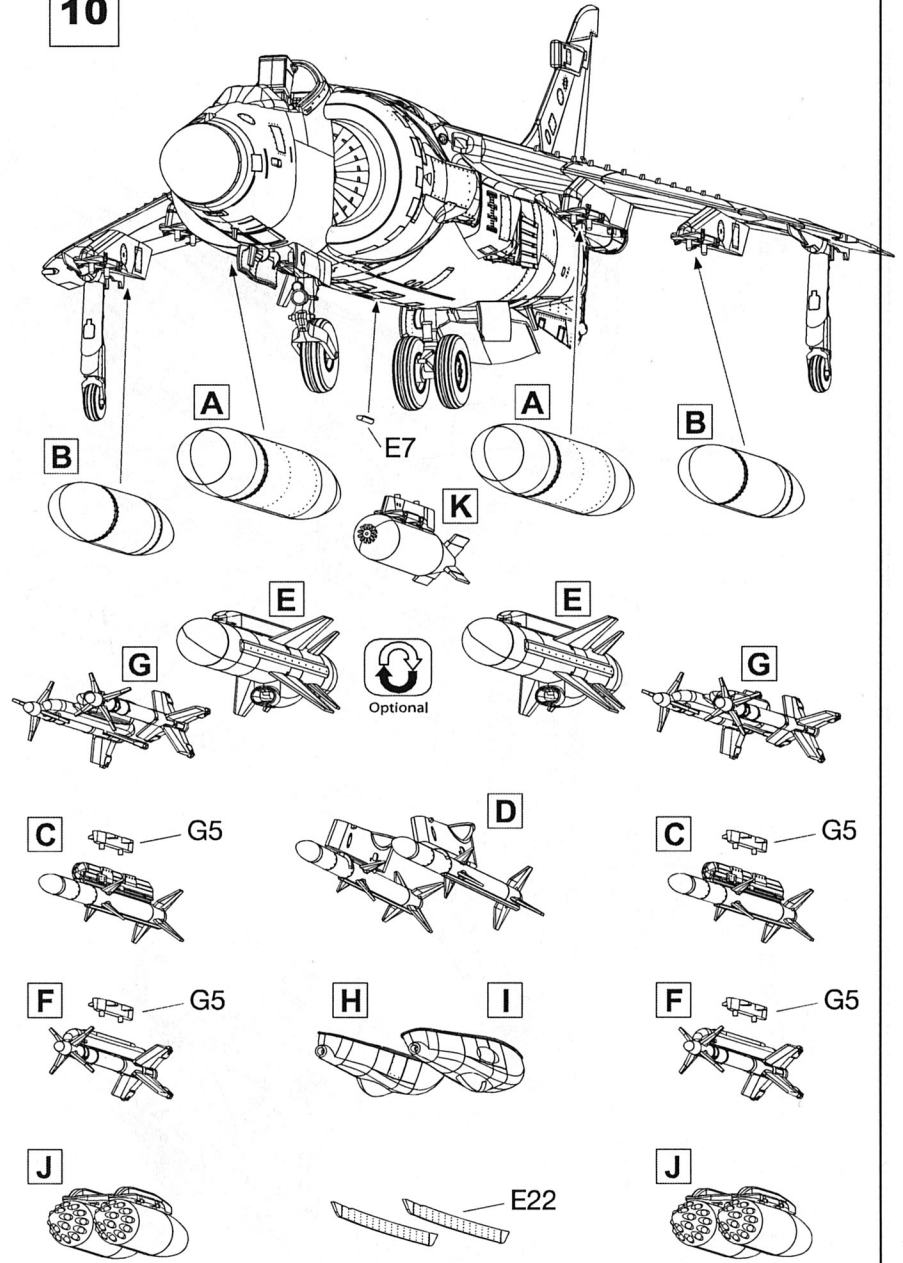

11

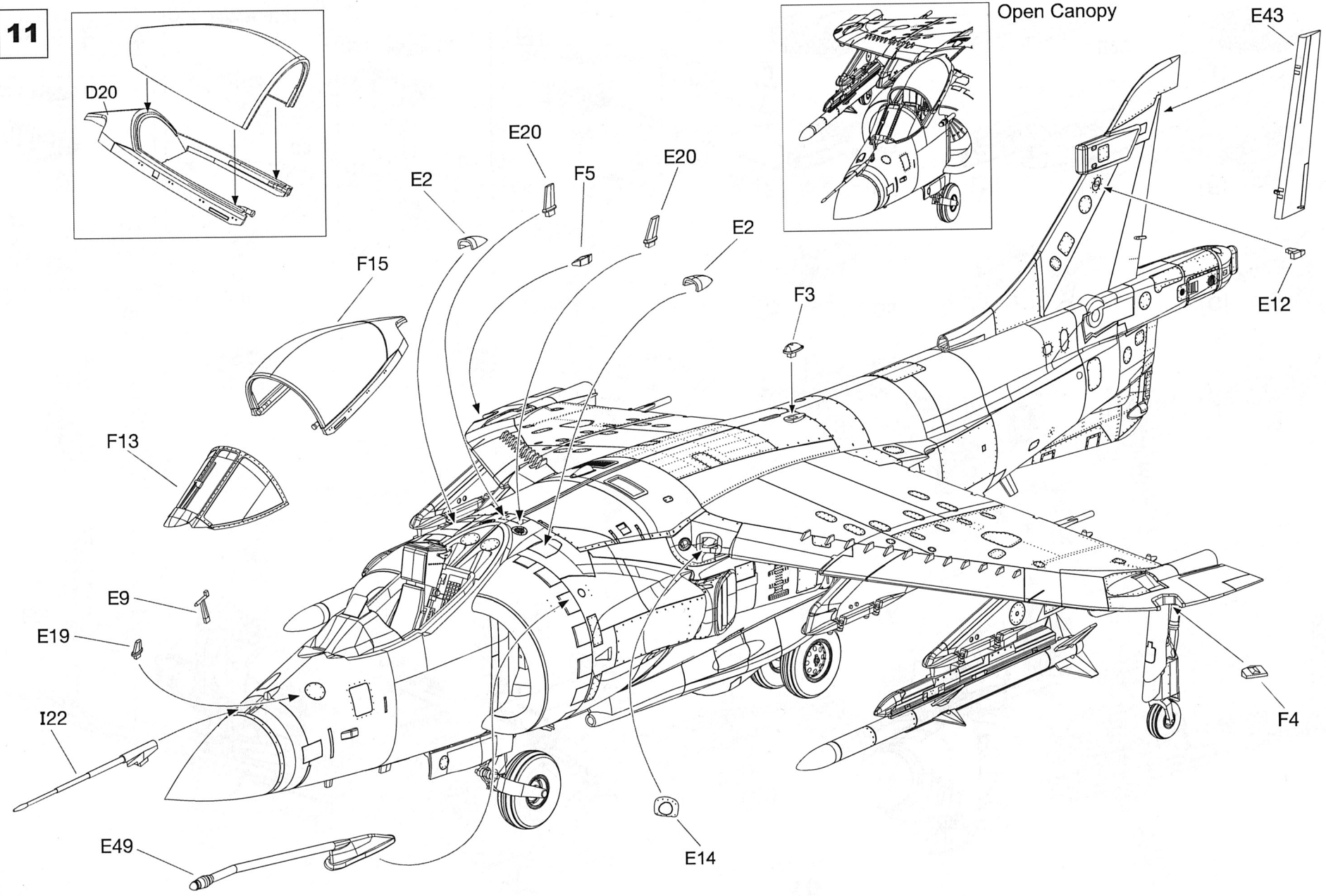
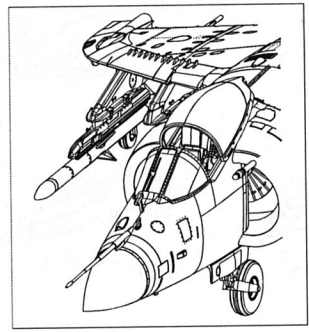
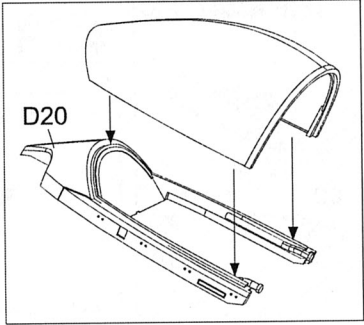

P-10

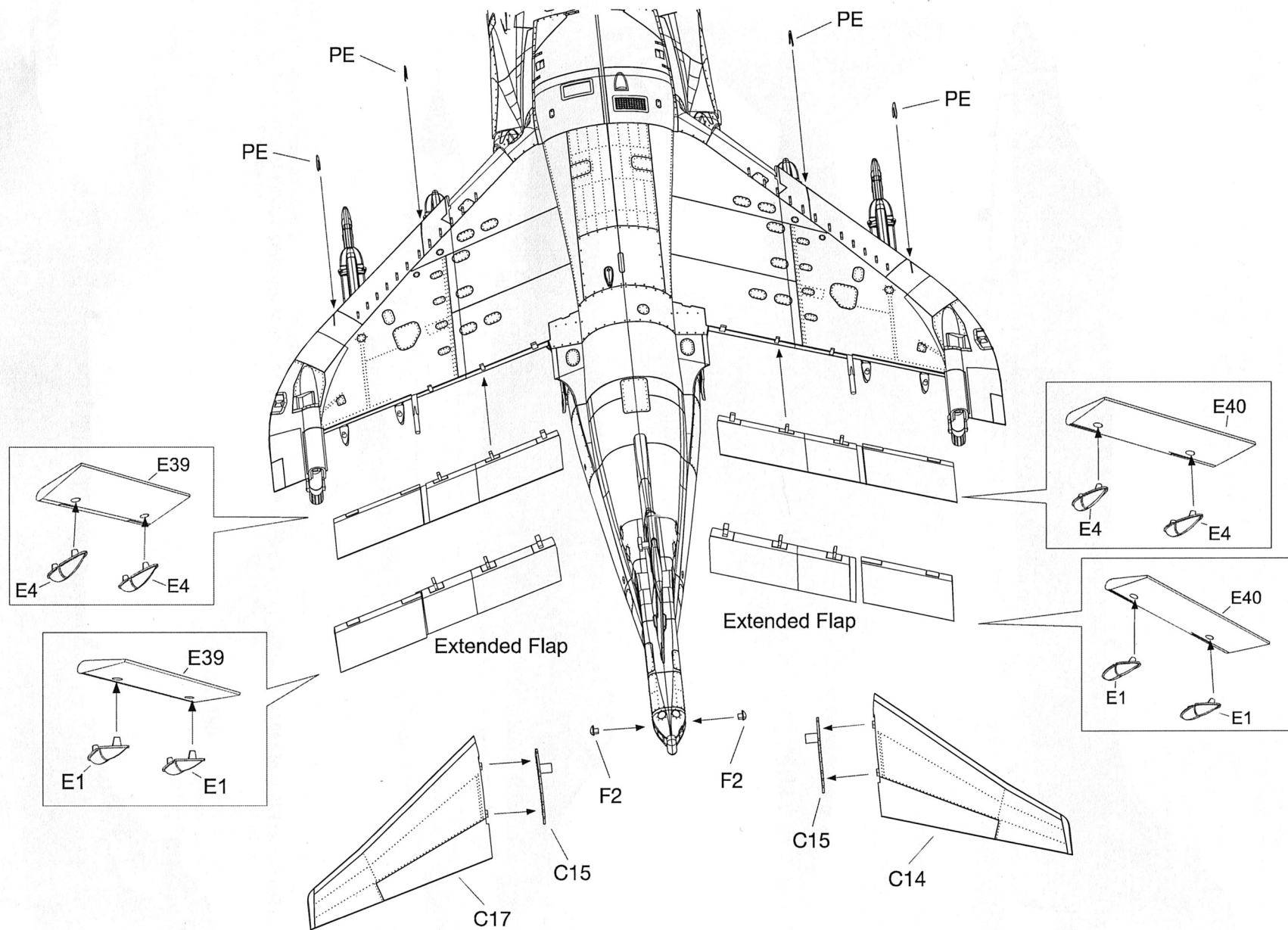

1/48 SCALE AIRCRAFT SERIES NO: K48035

1. BAe Sea Harrier FRS.1s of 800 Naval Air Squadron based at RNAS Yeovilton and deployed on HMS Hermes, 1981 to March 1982.

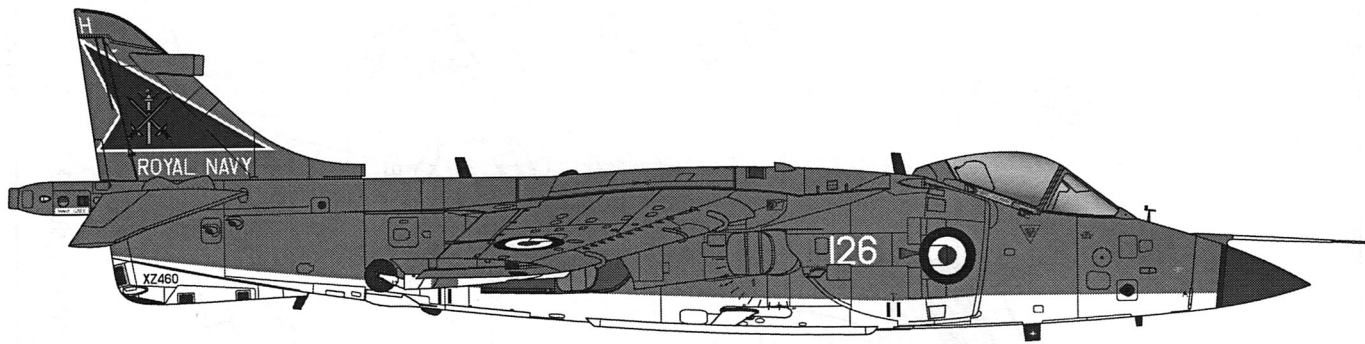

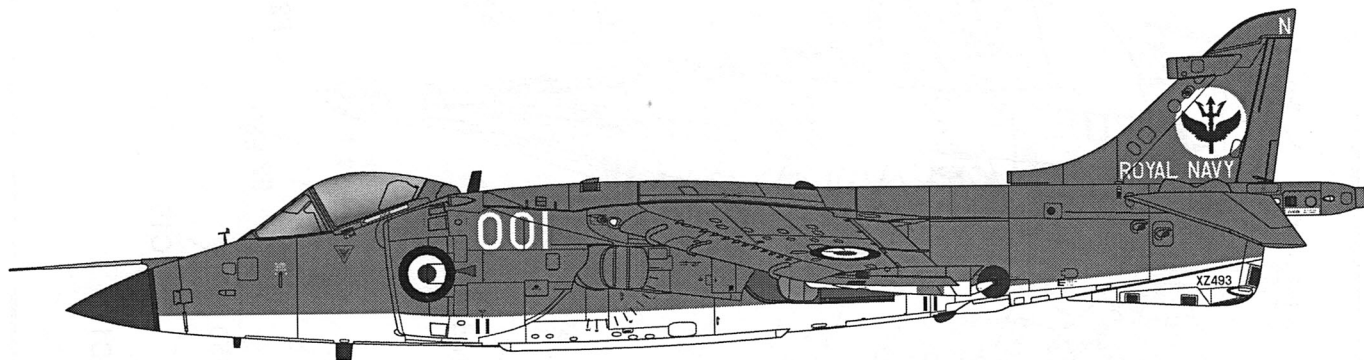

2. BAe Sea Harrier FRS.1s of 801 Naval Air Squadron based at RNAS Yeovilton and deployed on HMS Invincible, 1981 to March 1982.

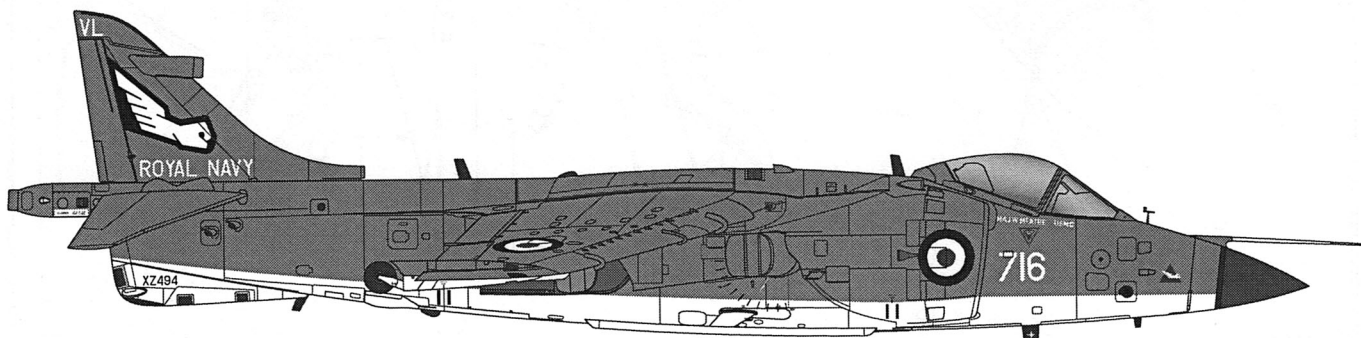

3. BAe Sea Harrier FRS.1s of 899 Naval Air Squadron based at RNAS Yeovilton, 1981 to March 1982.



1/48 SCALE AIRCRAFT SERIES NO: K48035

-  BS 381C - 640 Extra Dark Sea Grey
-  Satin White

Yellow bar markings on top of wing for initial schemes 1980 to April 1982 for: XZ452, XZ453, XZ457, XZ459, XZ460, XZ492, XZ493, XZ495, XZ496, XZ498. After April 1982, only kept on XZ452, XZ457 and XZ496; others overpainted EDSG

800 NAS, 1981 to Mar. 1982:

Use white 12" aircraft number on sides, and repeat its last digit to airbrake inside (black 12") and outrigger undercarriage (3").

Serial	A/C No.	Pilot Name	Mark
XZ492	123	60 - LT CDR AD AULD	"X" on centerline
XZ458	124	61 - LT CDR MS BLISSETT	
XZ459	125	62 - LT CDR GJ RAMSAY	UNUSUAL 5*
XZ460	126	63 - FLT LT EH BALL	"X" on centerline
XZ496	127		
XZ500	130	64 - LT M HALE	

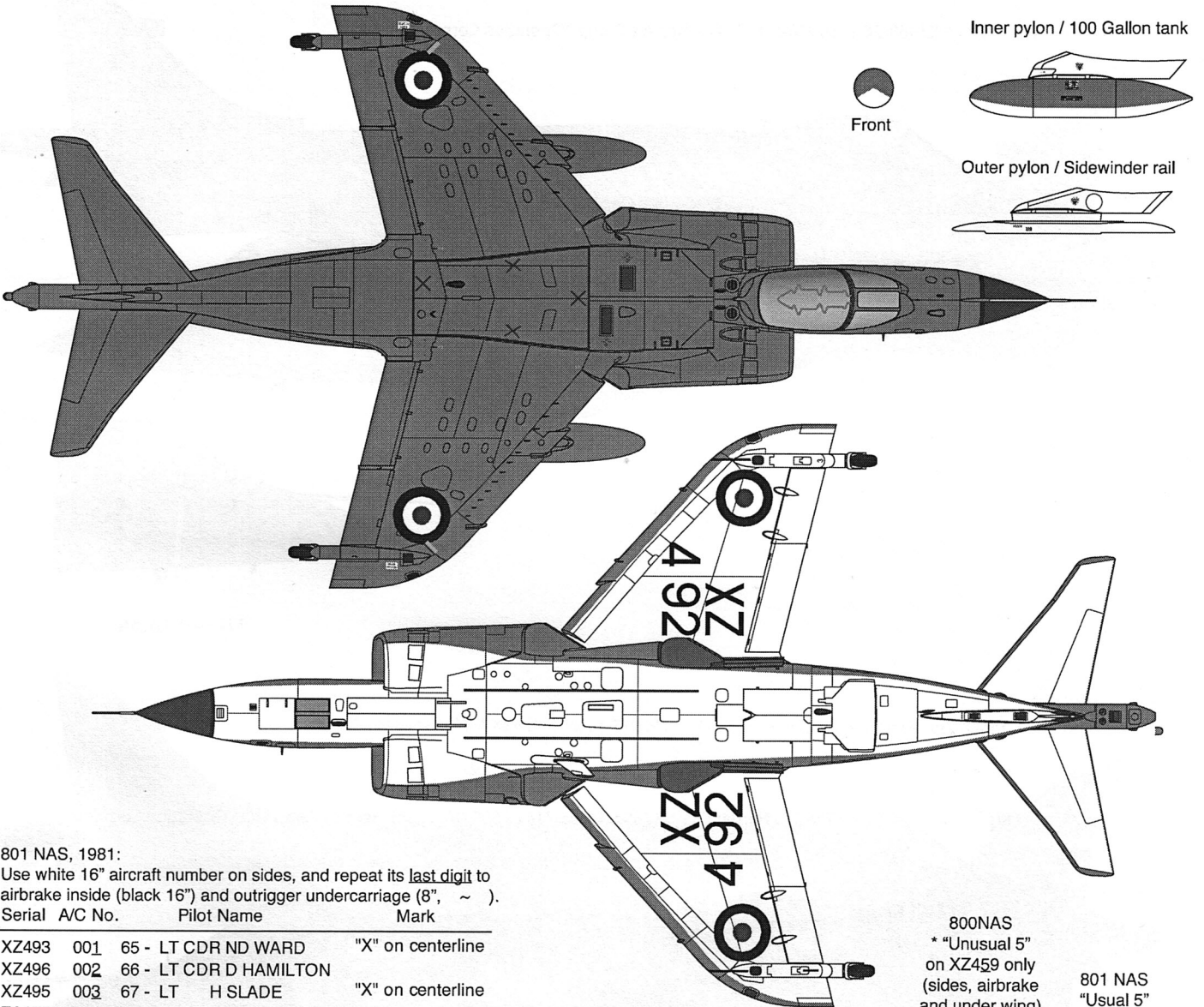

801 NAS, 1981:

Use white 16" aircraft number on sides, and repeat its last digit to airbrake inside (black 16") and outrigger undercarriage (8", ~).

Serial	A/C No.	Pilot Name	Mark
XZ493	001	65 - LT CDR ND WARD	"X" on centerline
XZ496	002	66 - LT CDR D HAMILTON	
XZ495	003	67 - LT H SLADE	"X" on centerline
ZA175	004		
XZ498	005		

800NAS
* "Unusual 5"
on XZ459 only
(sides, airbrake
and under wing)

801 NAS
"Usual 5"



Serial	A/C No.	Pilot Name	Mark
	~'81 '81~		

899 NAS, 1981:

Use white 12" aircraft number on cockpit sides.
No airbrake / outrigger number.

XZ451	100	710	68 - LT CDR / NW THOMAS	899 Zap
XZ452	101	711	69 - FLT LT PC BARTON	
XZ455	102	712	70 - LT CDR / RSG KENT	899 Zap
XZ456	103	713		899 ZAP / 3F Zap
XZ457	104	714	71 - LTCDR M BROADWATER ON 714	"X" on centerline, 899 Zap
XZ453	105	715	72 - FLTLT / A PENFOLD ON 105	
XZ494	106	716	73 - MAJ W MCATEE USMC	"X" on centerline, 899 Zap
ZA191		718		No "Mailed Fist" on fin

1/48 SCALE AIRCRAFT SERIES NO: K48035

4. BAe Sea Harrier FRS.1s of HMS Hermes' Air Group, "Operation Corporate" - The Falklands / Malvinas War, South Atlantic, Apr-Jun 1982. Aircraft, pilots and maintenance crews from 899 NAS were attached to 800 NAS on board HMS Hermes. While sailing south all white undersides, the first number of their side codes, pilot's names and all fin markings were overpainted Extra Dark Sea Gray (EDSG, by brush!); the white areas of the roundels being overpainted roundel blue. The newly painted EDSG and blue areas were slightly lighter than the original colours. Only a few underside stencil markings survived the overpainting. 12" high airbrake numbers were applied in black.

BAe Sea Harrier FRS.1 XZ460/26 of 800 NAS, HMS Hermes' Air Group, "Operation Corporate"

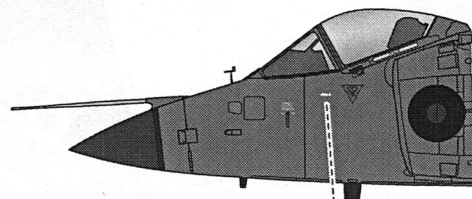
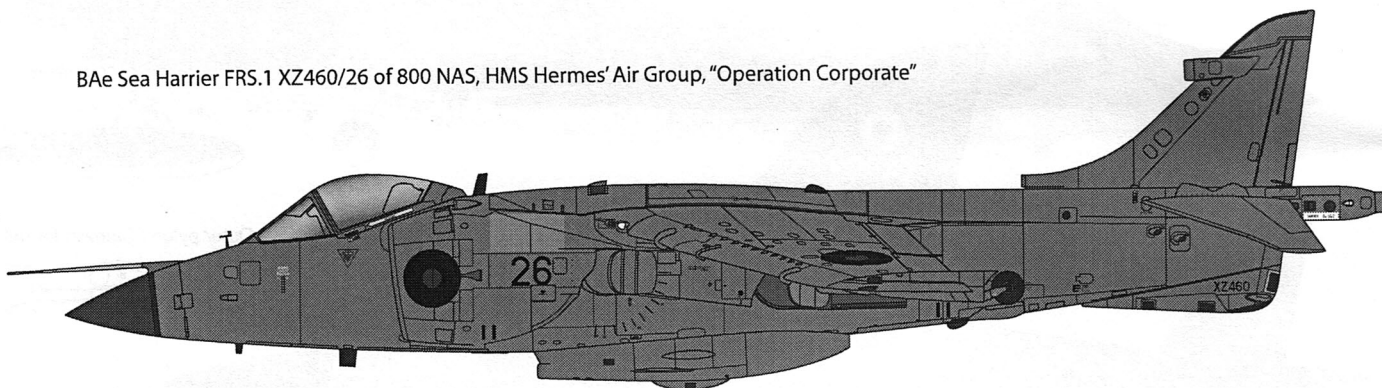

Killmark Location

BAe Sea Harrier FRS.1 XZ457/14, ex-714 of 899 NAS, HMS Hermes' Air Group, "Operation Corporate"

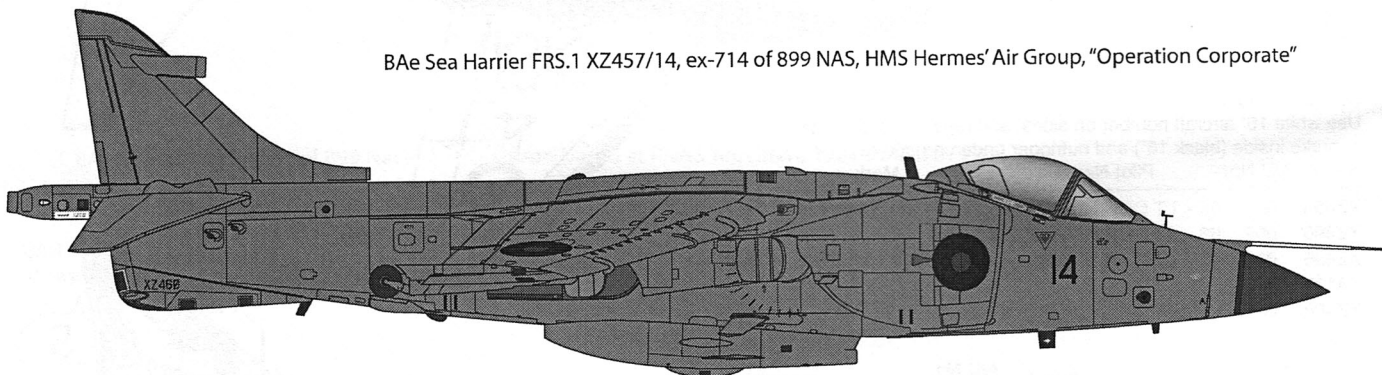

BS 381C - 640 Extra Dark Sea Grey

1/48 SCALE AIRCRAFT SERIES NO: K48035

5. BAe Sea Harrier FRS.1s of HMS Invincible's Air Group, "Operation Corporate" - The Falklands / Malvinas War, South Atlantic, Apr-Jun 1982. Aircrafts, pilots and maintenance crews from 899 NAS were also attached to 801 NAS on board HMS Invincible. While sailing south all white undersides, pilot's names and all fin markings were oversprayed Extra Dark Sea Gray; the white areas of the roundels being oversprayed roundel blue. Unlike with Hermes' Sea Harriers, it was impossible to distinguish the newly painted areas. Underside stencils appear to have been re-applied. The white side codes were overpainted roundel blue, and in the same color and height (16") to airbrake.

BAe Sea Harrier FRS.1 XZ493/001 of 801 NAS, HMS Invincible's Air Group, "Operation Corporate"

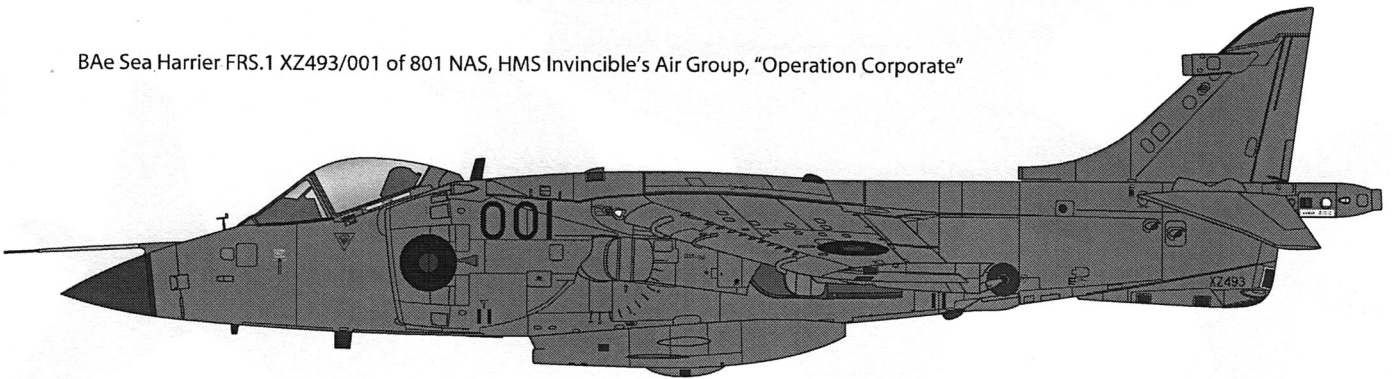

BAe Sea Harrier FRS.1 XZ451/006, ex-710 of 899 NAS, HMS Invincible's Air Group, "Operation Corporate"

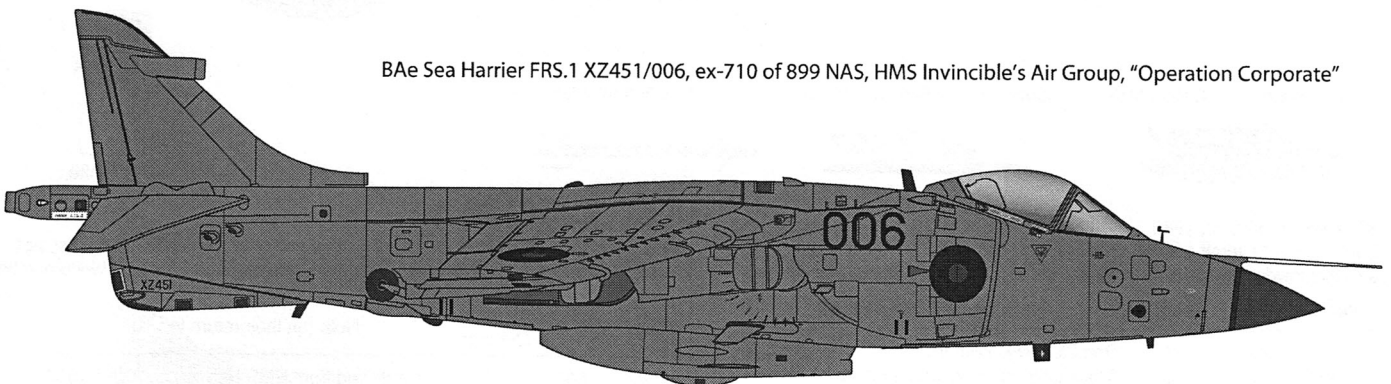

BS 381C - 640 Extra Dark Sea Grey

1/48 SCALE AIRCRAFT SERIES NO: K48035

5. BAe Sea Harrier FRS.1s of HMS Invincible's Air Group, "Operation Corporate" - The Falklands / Malvinas War, South Atlantic, Apr-Jun 1982. Aircrafts, pilots and maintenance crews from 899 NAS were also attached to 801 NAS on board HMS Invincible. While sailing south all white undersides, pilot's names and all fin markings were oversprayed Extra Dark Sea Gray; the white areas of the roundels being oversprayed roundel blue. Unlike with Hermes' Sea Harriers, it was impossible to distinguish the newly painted areas. Underside stencils appear to have been re-applied. The white side codes were overpainted roundel blue, and in the same color and height (16") to airbrake.

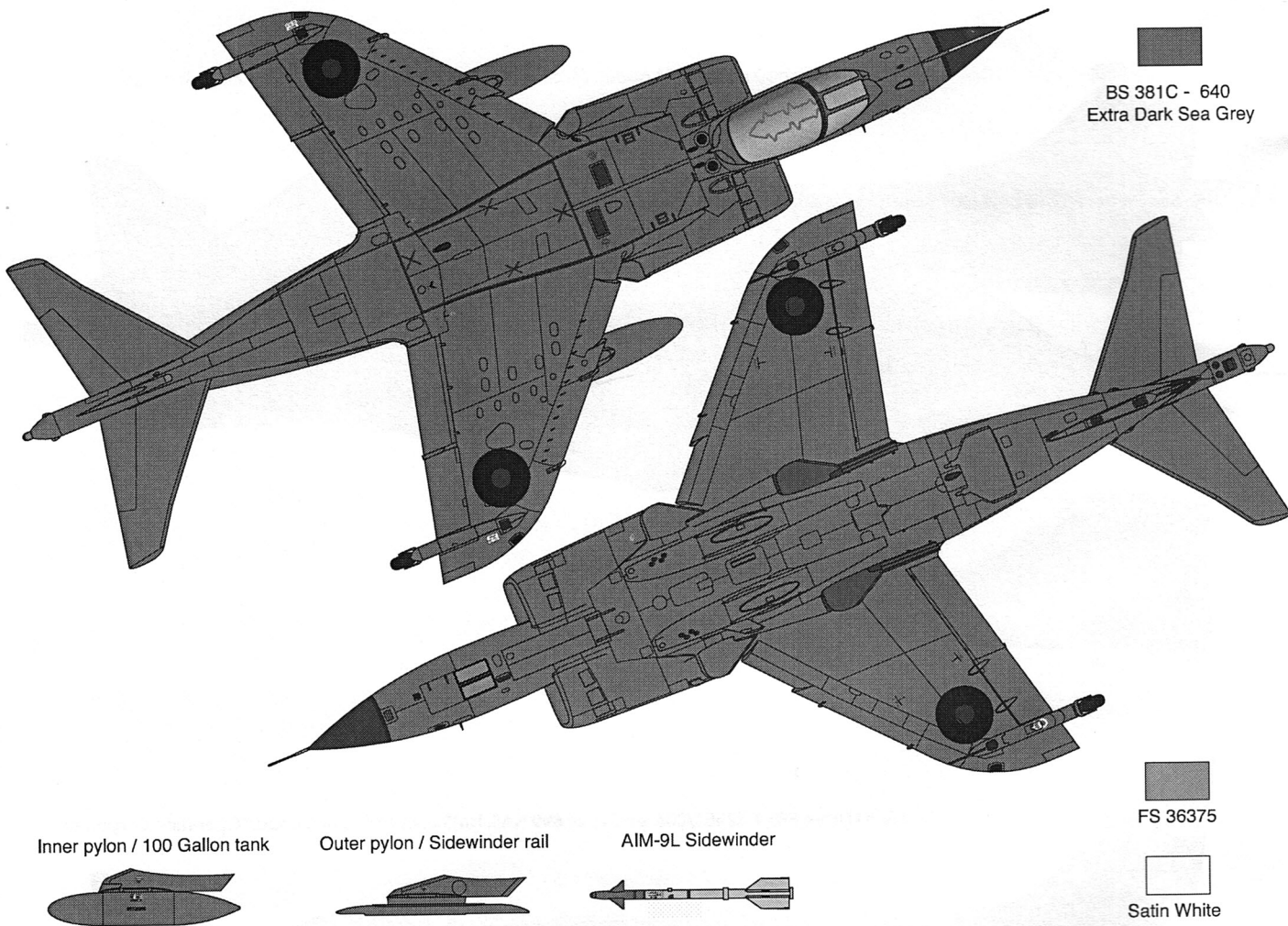

800 NAS on Hermes, 1982:

Use black 12" aircraft number on sides, and some aircraft had the last digit to airbrake inside. Numbers on outrigger undercarriage has been overpainted.

Serial	A/C No.	Airbrake	Note (on their return to UK)
XZ492	23	3	One Skyhawk killmark
XZ459	25	5	"Unusual 5" on sides and airbrake
XZ460	26	6	
XZ496	27	7	One Skyhawk killmark
XZ500	30	0	"30" and "0" in roundel blue, One A-4 killmark
XZ450	50	-	"X" on center
ZA192	92	-	
ZA193	93	-	"93" in roundel blue, Underwing roundel not repainted. One Dagger killmark.

Ex-899 NAS aircraft on Hermes, 1982: Same with 800 NAS aircraft, except the number location of cockpit sides.

Serial	A/C No.	Airbrake	Note (on their return to UK)
XZ455	12	2	Transferred to HMS Invincible became "000"
XZ457	14	4	One A-4, two Dagger killmark
XZ494	16	-	Transferred to HMS Invincible as "008"
ZA191	18	8	Carried two 1,000lbs Paveway LGB

801 NAS on Invincible, 1982:

Use roundel blue 16" aircraft number on sides and airbrake inside for the last digit. The last digit repeated on starboard outrigger undercarriage door in 8" white numbers

Serial	A/C No.	Airbrake & Outrigger	Note (on their return to UK)
XZ455	000	0	Transferred from HMS Hermes on 2, Jul, 1982 No stencils on cockpit sides
XZ493	001	1	"X" on center
XZ495	003	3	"X" on center
ZA175	004	4	Shot down one Dagger
XZ498	005	5	

Ex-899 NAS aircraft on Invincible, 1982: The same scheme as 801 NAS.

Serial	A/C No.	Airbrake & Outrigger	Note (on their return to UK)
XZ451	006	6	Victory against a Dagger and a Hercules
XZ452	007	7	Victory against a Mirage IIIEA Missing in action on 6, May.
XZ456	008	8	Shot down by Roland missile on 1, Jun.
XZ453	009	9	Damaged a Mirage IIIEA that failed to return. Missing in action on 6, May.

1/48 SCALE AIRCRAFT SERIES NO: K48035

6. BAe Sea Harriers FRS.1 of 809 NAS on establishment / en route to the South Atlantic for "Operation Corporate", late Apr / mid-May 1982

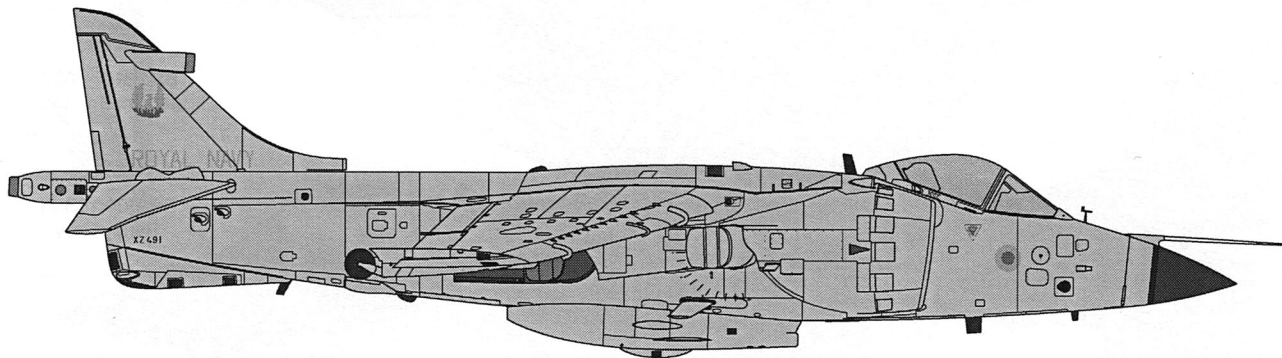

7. BAe Sea Harriers FRS.1 of ex-809 NAS as part of HMS Hermes' AirGroup, "Operation Corporate", late May / mid-Jun 1982

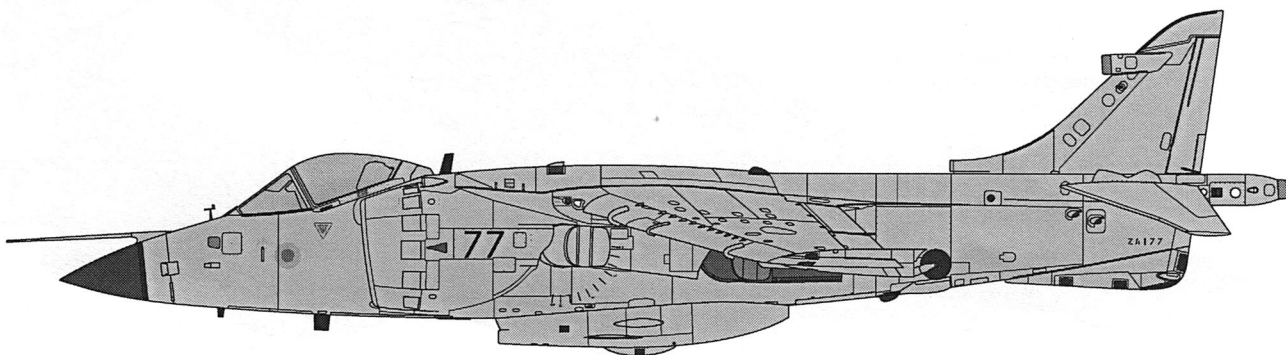

8. BAe Sea Harriers FRS.1 of ex-809 NAS as part of HMS Invincible's AirGroup, "Operation Corporate", late May / mid-Jun 1982

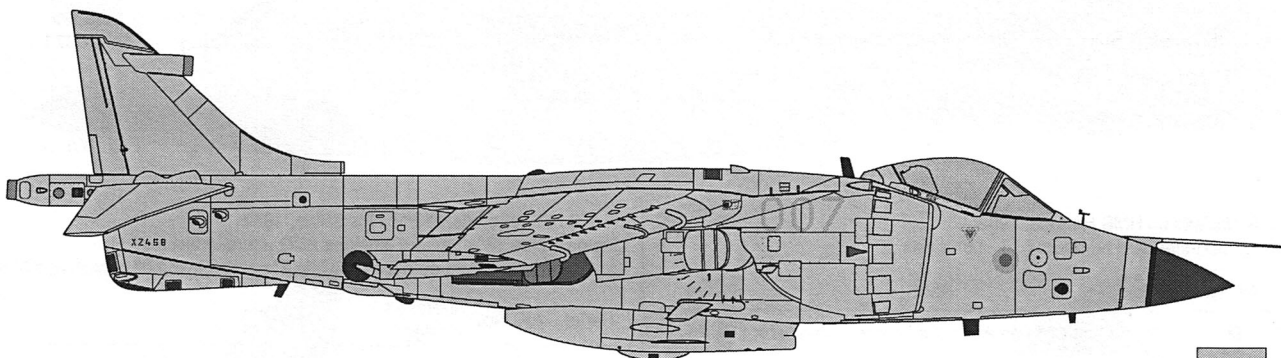

■
BS 381C - 637
Medium Sea Grey

1/48 SCALE AIRCRAFT SERIES NO: K48035

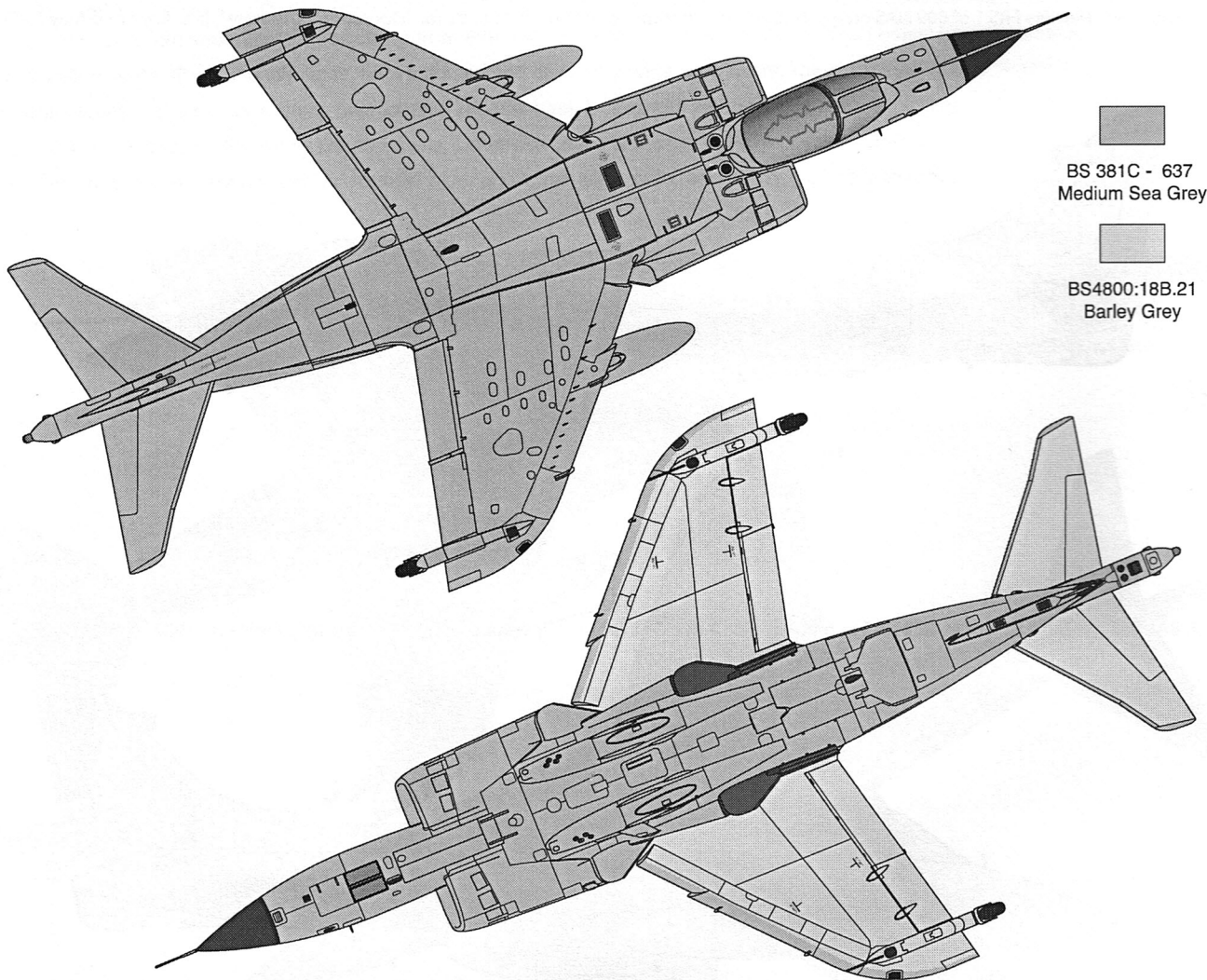

BS 381C - 637
Medium Sea Grey

BS4800:18B.21
Barley Grey

After HMS Hermes and HMS Invincible had sailed for the South Atlantic, all available Sea Harriers and pilots in the UK moved to RNAS Yeovilton where 809 Naval Air Squadron was stood up to form a new Sea Harrier Headquarters and Training Unit; taking on that role from 899 NAS. A decision was made to respray the aircraft in paler greys with toned down national and Squadron insignia to better equip them for combat at the altitudes and in the weather conditions expected in the South Atlantic. In the event the pilots found that at low and mid-levels over land and sea, where many of the combats took place, the paler SHARs were much more visible than the EDSG aircraft, which blended in superbly well with the sea and Falklands land colours. 809's SHARs flew out to Ascension Island and then sailed south on the Atlantic Conveyor, from where they flew to the carriers in mid-May. On the carriers they were given side codes and had their fin markings overpainted. Aircrafts of 809 NAS were equipped of the probe lights, on the root of port wing.

Inner pylon / 100 Gallon tank

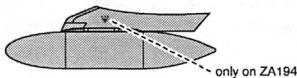

Outer pylon / Sidewinder rail

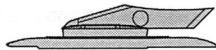

AIM-9L Sidewinder



FS 36375

Satin White

ex-809 NAS aircrafts on HMS Hermes, 1982:
Use black 12" non-standard numbers (~) on sides,

Serial	A/C No.	Serial	Note
XZ499	99	3"	Destroyed an A-4 but a Mirage is drawn for killmark
ZA176	76	4"	
ZA177	77	3"	Destroyed two A-4 but Mirages are drawn for killmark
ZA194	94	4"	Destroyed an A-4 but a Mirage is drawn for killmark Still had 20" underwing serial in black

ex-809 NAS aircrafts on HMS Invincible, 1982:
Use pale blue 16" numbers on sides AND airbrake inside.
Last digit repeated on outrigger in white 8" numbers and all aircraft had 3" serials.

Serial	A/C No.	Airbrake & outrigger	Note
ZA174	000	0	Operational loss on 29, May
XZ491	002	2	
XZ458	007	7	
ZA190	009	9	Destroyed two Daggers

1/48 SCALE AIRCRAFT SERIES NO: K48035

9. BAe Sea Harrier FRS.1 XZ493/H/123 of 800 Naval Air Squadron, "Exercise Arctic Express", HMS Hermes, 1983.

During Exercise Arctic Express off the Norwegian coast in Spring 1983, 338 Squadron Royal Norwegian Air Force 'zapped' XZ493/H/123 and XZ500/H/127 - the bow and arrow is from 338's crest. XZ493 was still overall Extra Dark Sea Grey with large out of proportion blue/red roundels as worn during the Falklands War. XZ500 was in the new overall Dark Sea Grey scheme with 16" blue/red fuselage roundels, 20" on the wings. The last digit of the side codes were carried in black on both outrigger fairings and inside the airbrake.

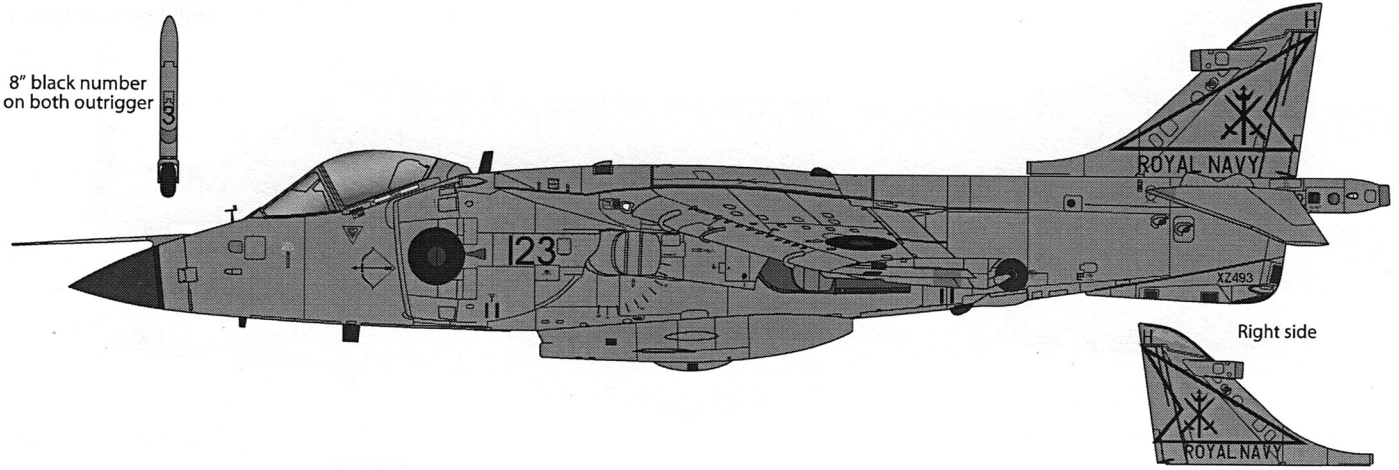

10. BAe Sea Harrier FRS.1 XZ451/000 of 801 Naval Air Squadron, HMS Invincible, 1983.
Had the last number ("0" on "000") on the airbrake inside in 12" black and outriggers in 8".

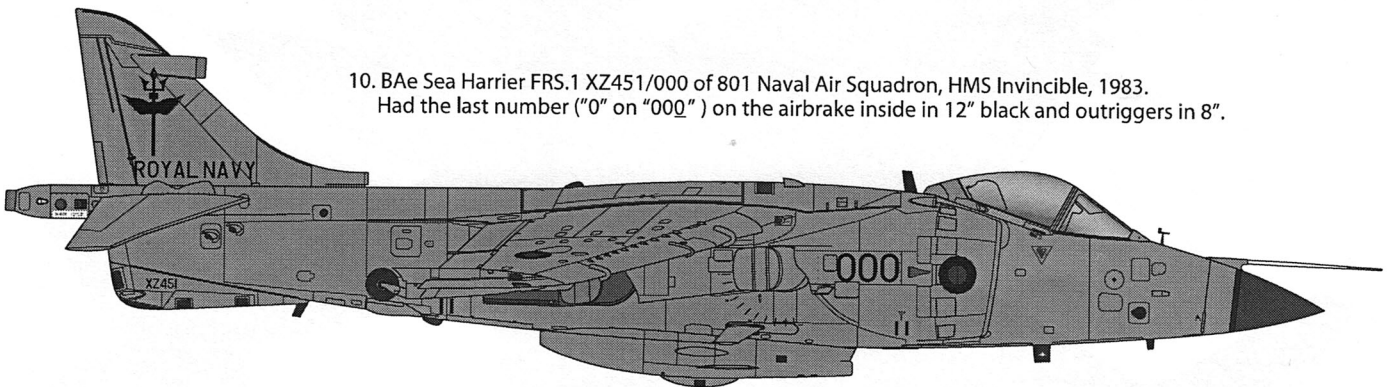

11. BAe Sea Harrier FRS.1 XZ455/712 of 899 Naval Air Squadron, RNAS Yeovilton, 1988.
Had the last number ("2" on "712") on the airbrake inside in 12" black.

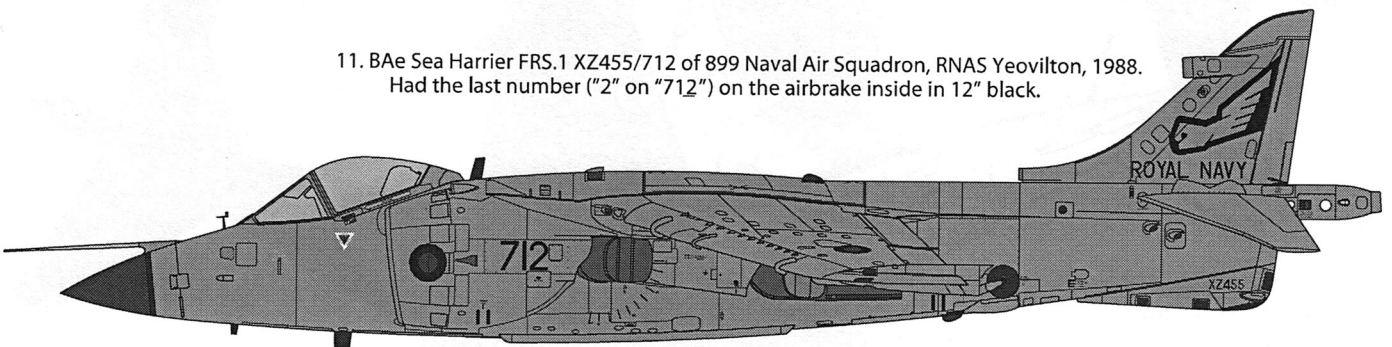

ZA176/N/001 1983

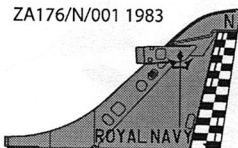

ZA176/R/007 1989

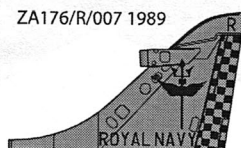

ZD614/004 1992

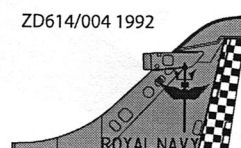

1/48 SCALE AIRCRAFT SERIES NO: K48035

12. BAe Sea Harrier FRS.1 XZ491 of 809 NAS as seen at the RNAS Yeovilton Air Show on 31 July 1982 and then deployed to the South Atlantic with 809 NAS on board HMS Illustrious between August and December 1982, in DSG / BG scheme. For this deployment 809's side codes were in the 250~259 range and the aircraft also acquired names and minimalist nose art towards the end of the deployment.

8" black number
on both outriggers

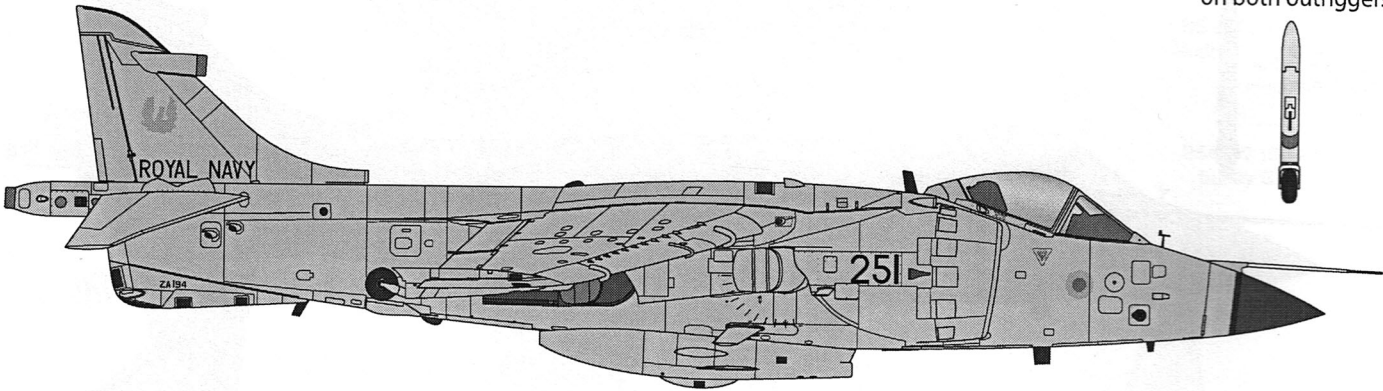

800 / 801 / 899 NAS aircrafts

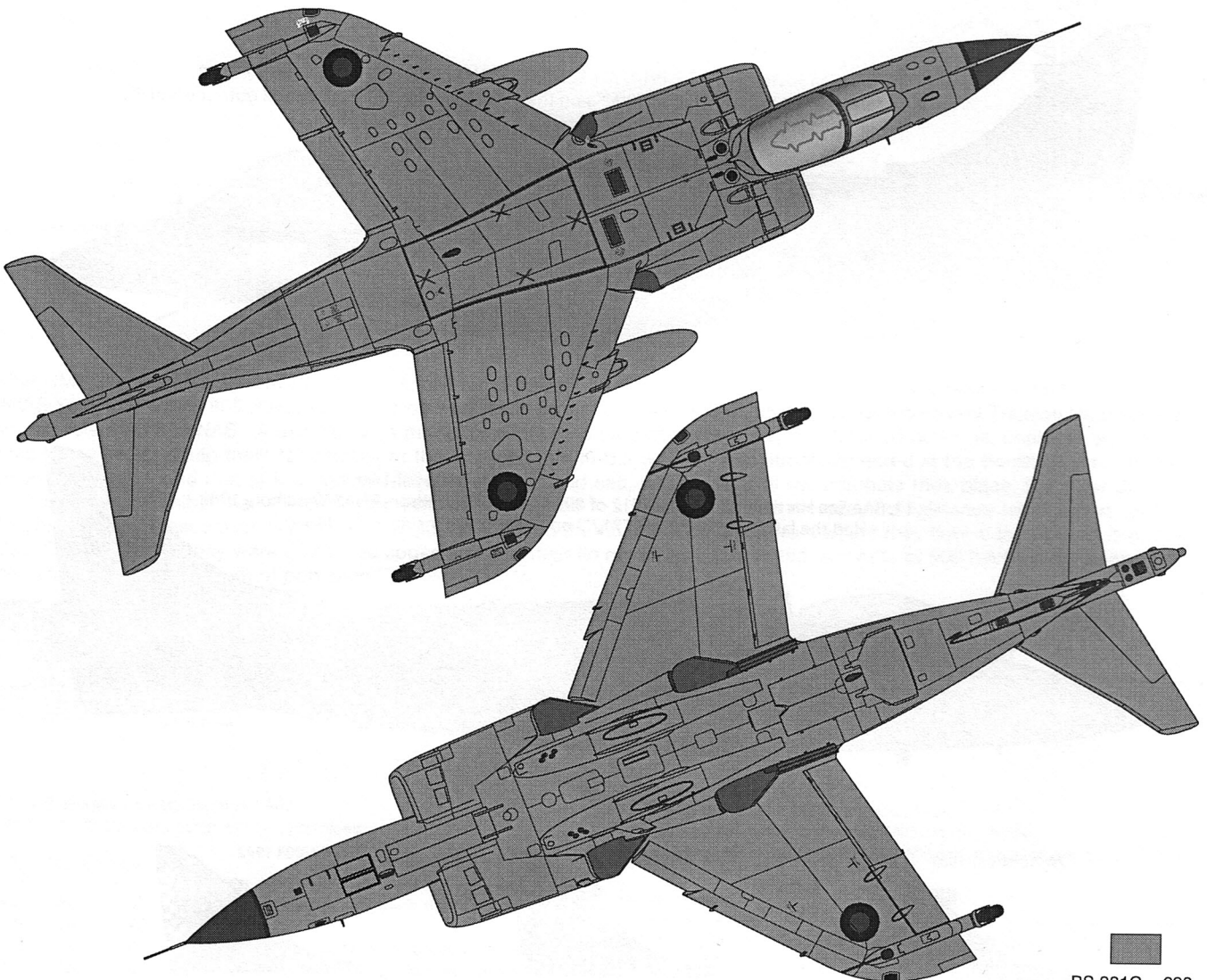

BS 381C - 638
Dark Sea Grey

1/48 SCALE AIRCRAFT SERIES NO: K48035

13. BAe Sea Harrier FRS.51s of 300 Indian Naval Air Squadron, 1983.

■ BS 381C - 640 Extra Dark Sea Grey

□ Satin White

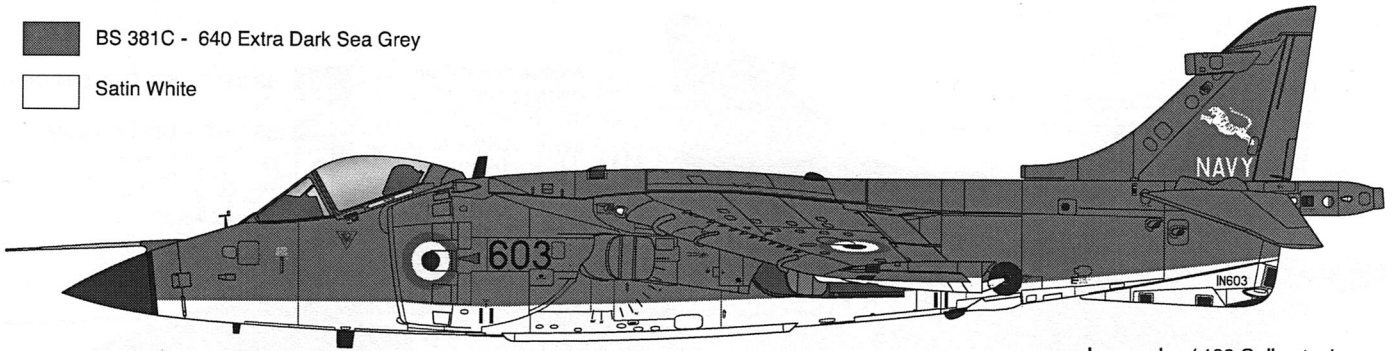

Inner pylon / 100 Gallon tank

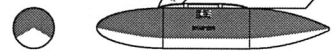

800 / 801 / 899 NAS aircrafts

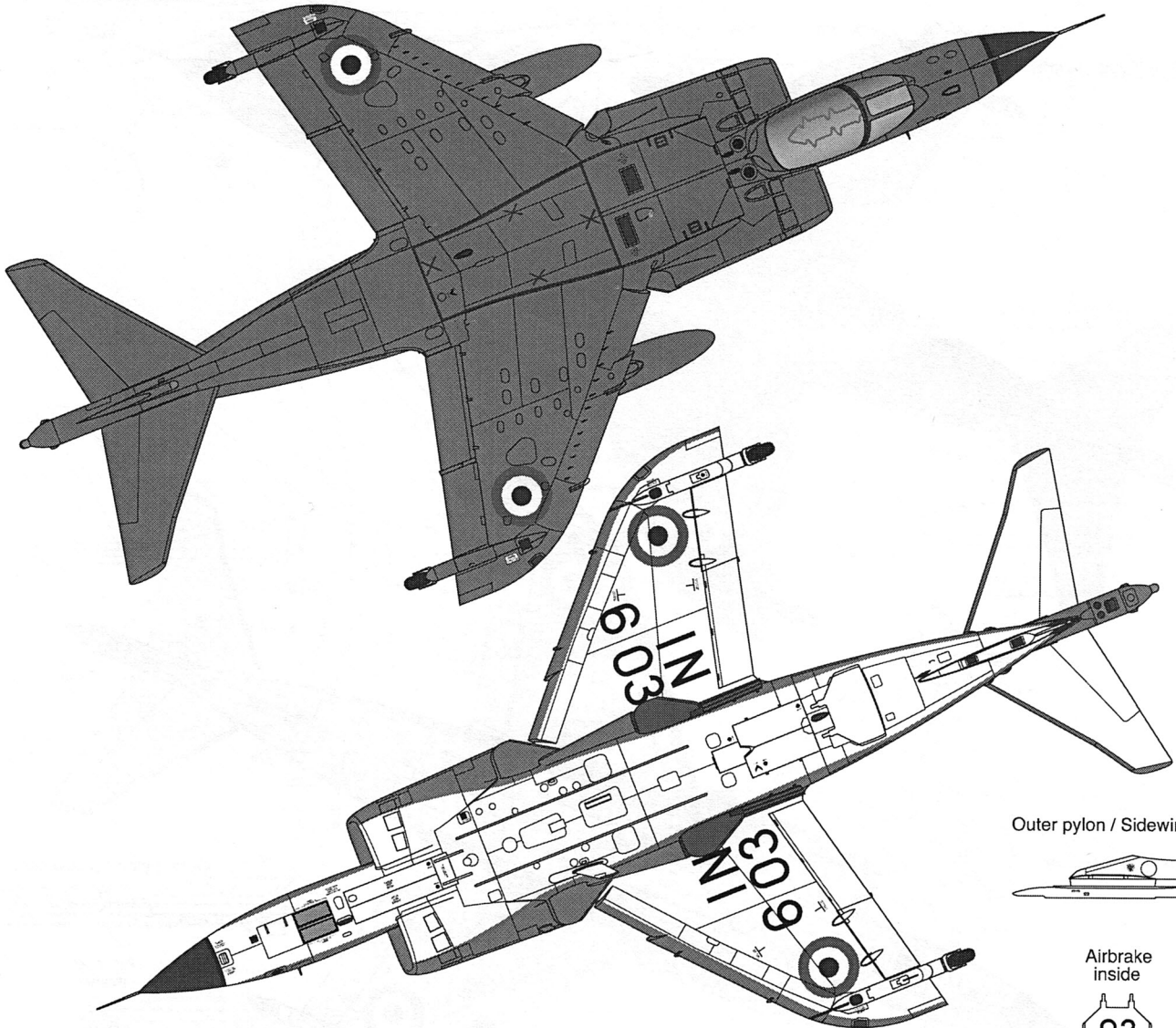

Outer pylon / Sidewinder rail



Airbrake
inside



TWO digit in 12" black

1/48 SCALE AIRCRAFT SERIES NO: K48035

14. BAe Sea Harrier FRS.51s of 300 Indian Naval Air Squadron, 2005.

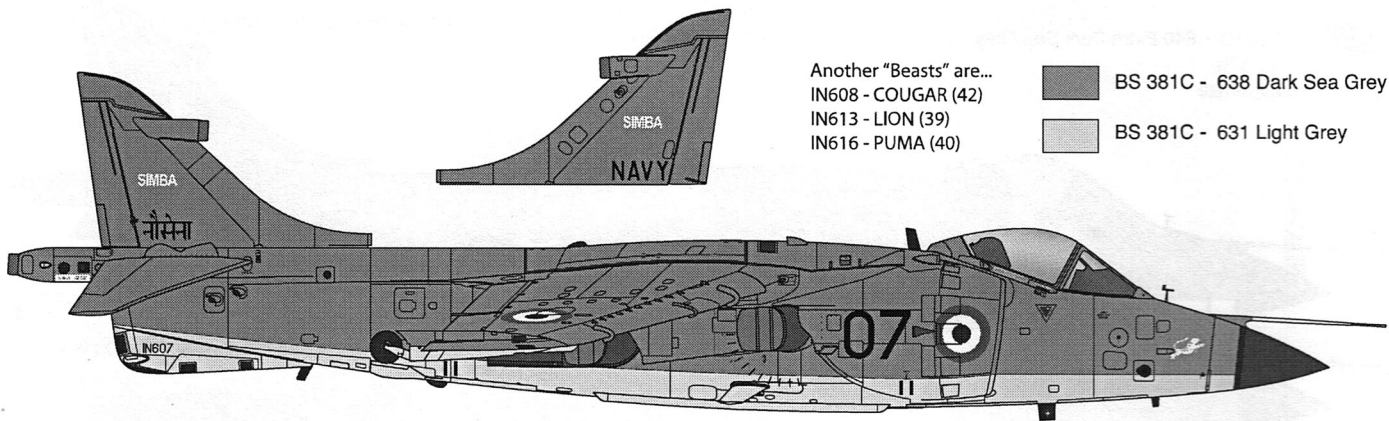

Another "Beasts" are...
IN608 - COUGAR (42)
IN613 - LION (39)
IN616 - PUMA (40)

- BS 381C - 638 Dark Sea Grey
- BS 381C - 631 Light Grey

Inner pylon / 190 Gallon tank

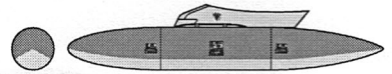

800 / 801 / 899 NAS aircrafts

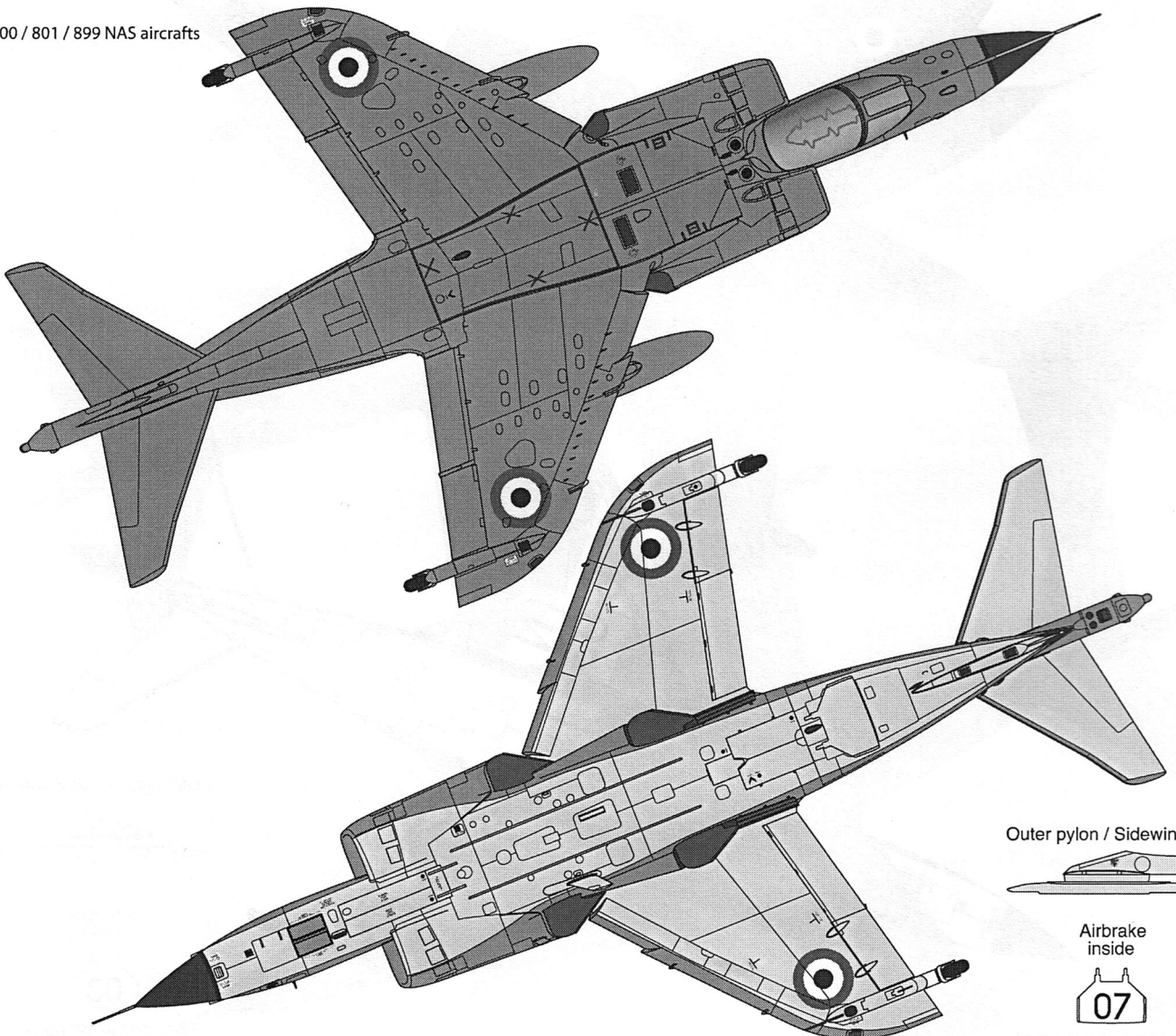

Outer pylon / Sidewinder rail



Airbrake inside



TWO digit in 12" black

1/48 SCALE AIRCRAFT SERIES NO: K48035

Common Markings

